

***Hustler® Raptor
CE Parts Manual***



HUSTLER®

ENGINEERING PERFORMANCE™

200 South Ridge Road
Hesston, Kansas
67062

Table of Contents

General Information

Service Literature	1-1
Options Available From Your Dealer	1-1
Using This Manual	1-1
Hardware Description Codes & Abbreviations	1-2
Standard Torques	1-2

Section 2

Frame	2-2
Fenders & Instrument Panel	2-4
Battery	2-6

Section 3

Hydraulic System	3-2
Transmission Assembly	3-4
Transmission Service Parts	3-6
Steering & Brake	3-8
Steering Cover Assembly	3-10

Section 4

Wheel & Tire—36" Mowers	4-2
Wheel & Tire—42" Mowers	4-4
Front Wheel Breakdown	4-6
Drive Wheel Breakdown—36" Mowers	4-8
Drive Wheel Breakdown—42" Mowers	4-9

Section 5

Engine, Kawasaki	5-2
Engine Service Parts, Kawasaki	5-6
Fuel System	5-8
Fuel Tank Service Parts	5-10

Section 6

36" Service Deck	6-2
36" Deck Pulleys & Spindles	6-4
36" Deck	6-6
36" Guards	6-8
42" Service Deck	6-10
42" Deck Pulleys & Spindles	6-12
42" Deck—S/N 14030001 & Higher	6-14
42" Deck—S/N Prior to 14030001	6-16
42" Guards	6-18
36"/42" Deck Lift	6-20

Section 7

Seat	7-2
----------------	-----

General Information

This manual covers Hustler® Raptor models **932277CE & 933382CE**.

Service Literature

PART NO.	DESCRIPTION
604220CE	OPERATOR'S MANUAL
117371EX	WARRANTY STATEMENT
117373	GENERAL SERVICE MANUAL

Options Available From Your Dealer

PART NO.	DESCRIPTION
119937	36" MULCH KIT
117578	42" MULCH KIT
333724	STEERING LEVER EXTENSION KIT
933010	2 BAG CATCHER
604436	ARM REST KIT
117703	HOUR METER KIT
799288	FLEX FORKS KIT
117682	LIGHT KIT
119818	ENGINE GUARD KIT

Note: When ordering parts, you must use the part number as shown for each part, not the index number. Always give the model and serial number to your parts and service representative.

Note: Items sold in bulk such as seals and hoses are sold by the foot.

Using This Manual

This manual is part of a service package for the Hustler® mowers. Use of this manual in conjunction with other Hustler® mower and component manuals will provide the information necessary to service and maintain Hustler® mowers.

This Parts Manual provides a complete parts listing for the unit. Use this manual when ordering parts. Illustrations used were current at the time of printing, but subsequent production changes may cause your machine to vary slightly in detail. Excel Industries, Inc. reserves the right to redesign and change the machine as deemed necessary, without notification. If a change has been made to your machine which is not reflected in this parts manual, see your authorized dealer for current information and parts.

The Service Manual is a service guide for use by Service Technicians. It provides the necessary information needed to perform normal maintenance requirements on these units.

The Operator's Manual provides fundamental operational information and operational safety that is needed when operating the mower.

The component manuals are furnished by the various manufacturers to be used for the troubleshooting and servicing of their products.

Hardware Description Codes & Abbreviations

The following codes are used throughout this parts manual. Refer to this list when ordering parts.

ABBREVIATION	DESCRIPTION	ABBREVIATION	DESCRIPTION
CB	CARRIAGE BOLT	MB	MACHINE BUSHING
CE	CLEVIS PIN	MS	MACHINE SCREW
CN	CLIP NUT	NT	NUT
CP	COTTER PIN	SC	SELF TAPPING CAP SCREW
CS	CAP SCREW	SH	SOCKET HEAD
CW	CUP WASHER	SB	SHOULDER BOLT
FDRW	FENDER WASHER	SS	SET SCREW
FW	FLAT WASHER	OD	OUTSIDE DIAMETER
HX	HEX HEAD	ID	INSIDE DIAMETER
LW	LOCK WASHER		

Standard Torques

The following chart lists the standard torque values for the threaded fasteners found in this manual. Torque all cap screws, nuts and set screws to these values unless a different torque is shown in the Notes section next to the fastener.

SIZE	FT-LBS	N-M	SIZE	FT-LBS	N-M
.250	8.2	11.1	M3	1	1.3
.312	17	23	M4	2.2	3
.375	30	40	M5	4.5	6.1
.438	48	65	M6	7.7	10.4
.500	73	99	M8	18.5	25
.562	105	143	M10	37	50
.625	145	200	M12	64	87
.750	260	350	M14	80	108.5
.875	420	565	M16	160	215
1.00	625	850	M20	320	435
			M24	555	750

Section 2

Frame	2-2
Fenders & Instrument Panel	2-4
Battery	2-6

Frame

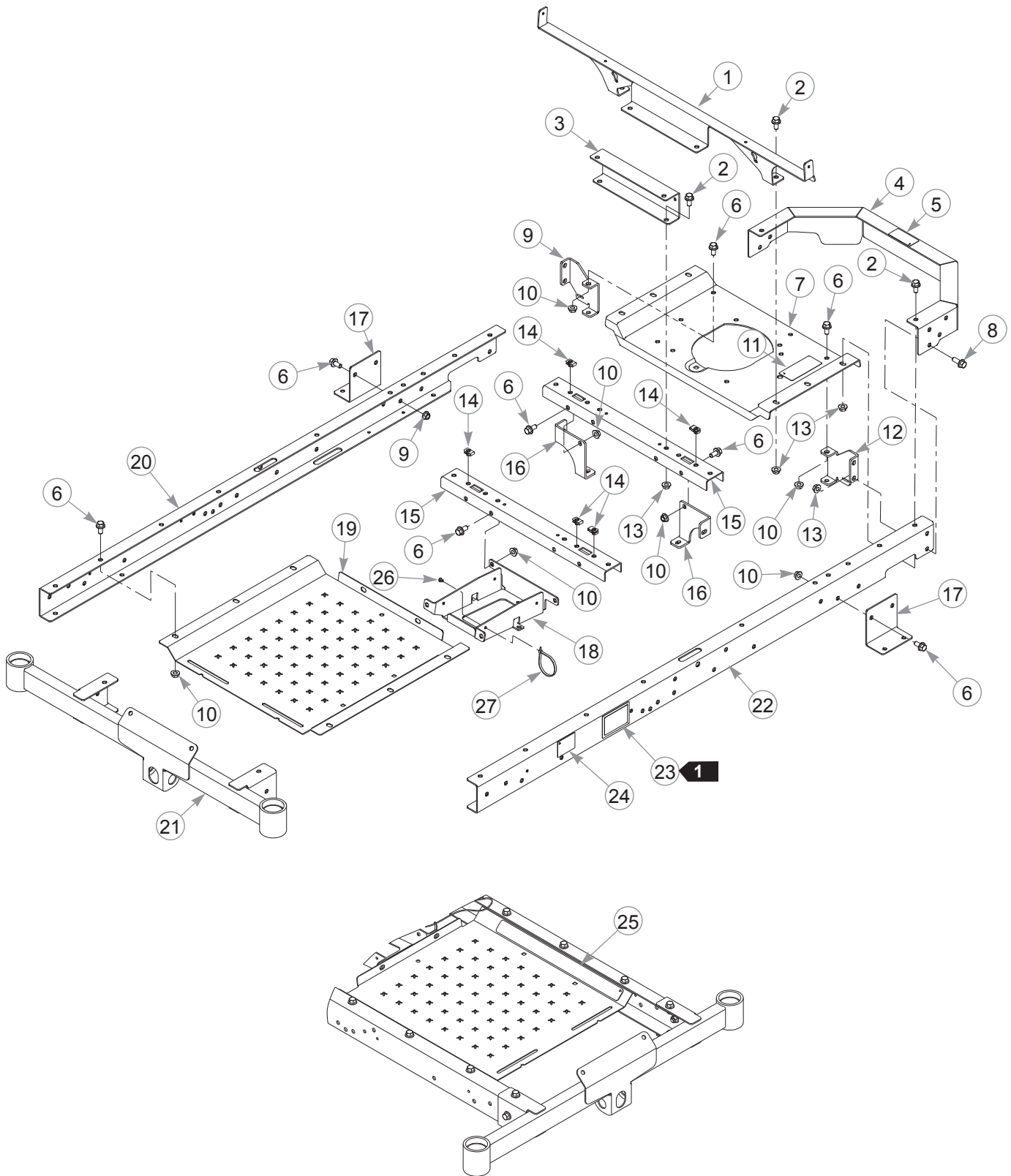

Frame

INDEX NO.	PART NO.	QTY.	DESCRIPTION
1	116126	1	SEAT SUPPORT
2	029629	6	CS .375-16 X .75 HX FLK
3	116127	1	SPRING SUPPORT
4	551857	1	BUMPER (WITH DECAL)
5	602041	1	HOT DECAL
6	604176	30	CS .375-16 X .75 HX FLK PLN
7	551858	1	ENGINE PLATE (WITH DECAL)
8	029751	4	CS .375-16 X 1.00 XH FLK
9	551859	1	RS REAR BRACKET
10	604177	30	NT .375-16 HX FLK PLN
11	601967	1	ENGINE COMPARTMENT DECAL
12	551860	1	LS REAR BRACKET
13	016899	10	NT .375-16 HX FLK G5
14	601982	5	CN .250-20 X .15 MAX THK
15	551861	2	CROSS SUPPORT
16	551862	2	RS FRONT BRACKET
17	551863	2	HYDRO BRACKET
18	551864	1	BATTERY TRAY
19	551865	1	FOOT PAN (WITH DECAL)
20	551866	1	RS FRAME CHANNEL
21	551867	1	FRONT CROSS FRAME
22	551868	1	LS FRAME CHANNEL (WITH DECALS)
23	N/A	1	SERIAL NUMBER / SPEC DECAL
24	776310	1	CE MARK DECAL
25	601981	1	SAFE OPERATION DECAL
26	604307	6	PUSH BUTTON MOUNT
27	000331	6	WIRE TIE

NOTES:

1. Serial number decal. In the event the serial number tag becomes damaged or illegible, please contact your dealer to order a replacement.
2. Torque all hardware to a minimum of 45 N•m.

Fenders & Instrument Panel

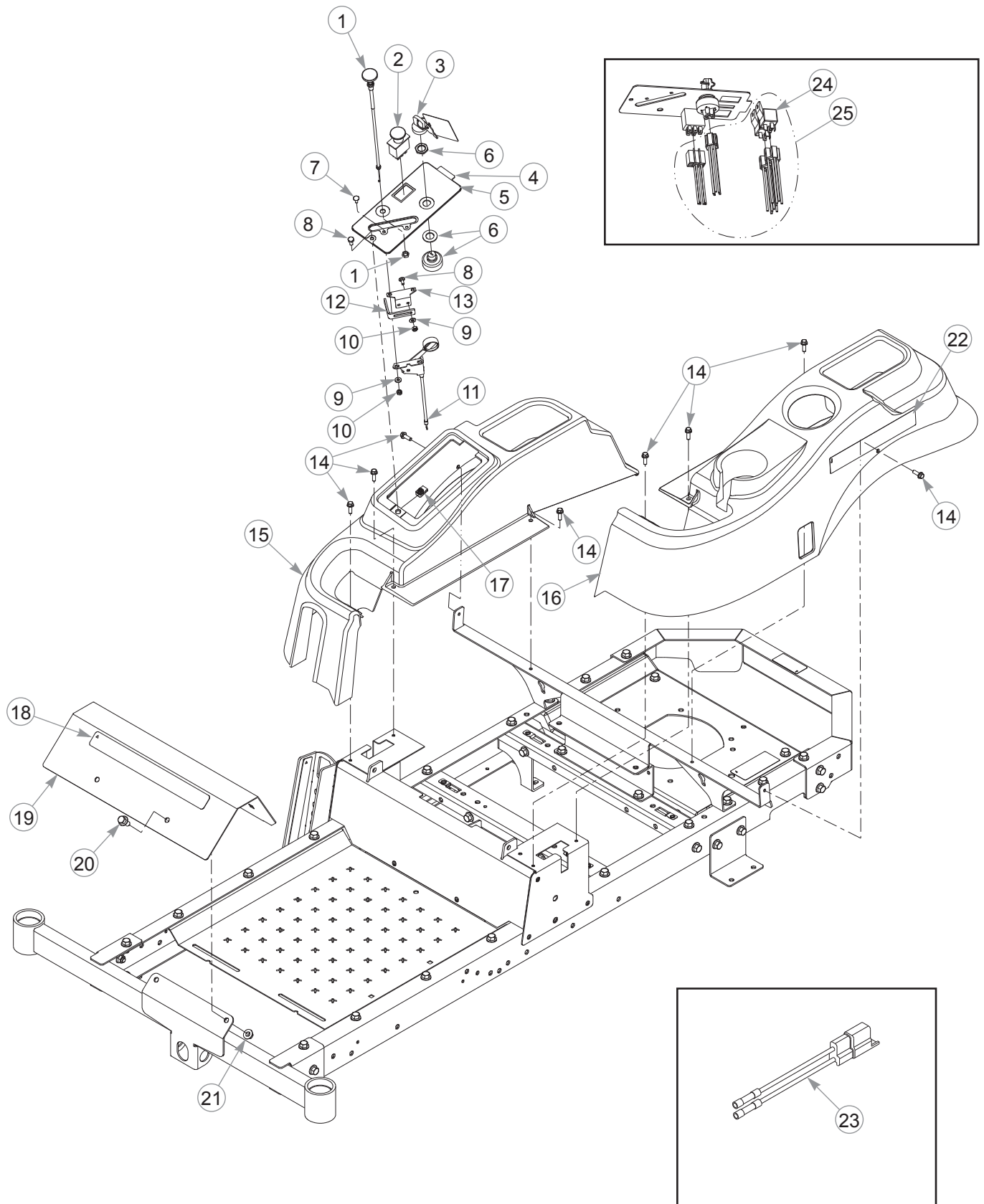

Fenders & Instrument Panel

INDEX NO.	PART NO.	QTY.	DESCRIPTION
1	601097	1	CHOKE CABLE
2	776476	1	PTO SWITCH
3	785808	1	KEY ASSEMBLY
4	551898	1	INSTRUMENT PANEL (WITH DECAL)
5	604196	1	INSTRUMENT PANEL DECAL
6	045898	1	IGNITION SWITCH
7	055947	1	CS .250-20 X .500 HX G5
8	601098	4	CB 10-24 X .500 ZYNC
9	704932	4	FW .219 X .500 X .048 ZNYC
10	059832	4	NT #10-24 HX NL ZN
11	601096	1	THROTTLE CABLE
12	117793	1	THROTTLE STOP
13	117795	1	THROTTLE STOP BRACKET
14	604324	8	CS .250-20 X .75 HX FLG
15	552809	1	RS FENDER (WITH DECAL)
16	552810	1	LS FENDER (WITH DECAL) - 604125 senza decal (25-08-15)
17	601982	1	CN .250-20 X .15 MAX THK
18	602407	1	HUSTLER ID DECAL
19	116162	1	FOOTREST
20	029629	2	CS .375-16 X .75 HX FLK
21	016899	2	NT .375-16 HX FLK G5
22	604388	2	RAPTOR DECAL
23	114052	1	CLUTCH CONNECTOR REPAIR KIT
24	601053	2	SEALED RELAY (WITH BRACKET)
25	604876	1	WIRE HARNESS

NOTES:

Battery

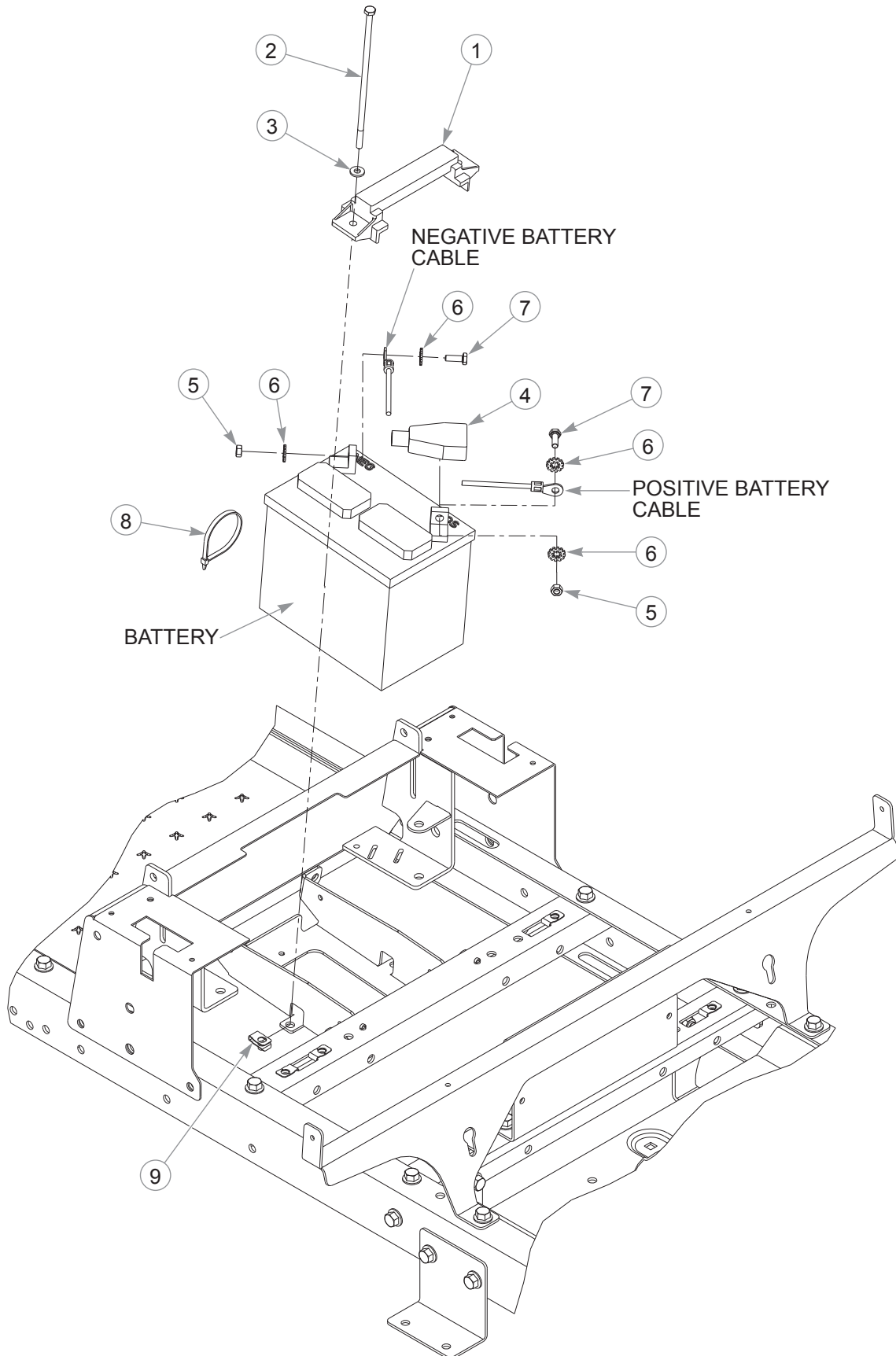

Battery

INDEX NO.	PART NO.	QTY.	DESCRIPTION
1	604178	1	TIE DOWN STRAP
2	604465	2	CS 0.250-20 X 7.50 HX G5
3	768515	2	FW .281 X .625 X .066
4	771428	1	RED BATTERY CABLE BOOT
5	024927	2	NT .250-20 HX G5 ZNYC
6	029868	4	LW .250 INT-EXT TOOTH Z
7	055939	2	CS .250-20 X .75 HX G5
8	000331	2	WIRE TIE
9	601982	2	CN .250-20 X .15 MAX THK

NOTES:

1. When performing service on the mower, disconnect the negative battery cable and do not reconnect it to the battery until ready to start the engine.

Section 3

Hydraulic System	3-2
Transmission Assembly	3-4
Transmission Service Parts	3-6
Steering & Brake	3-8
Steering Cover Assembly	3-10

Hydraulic System

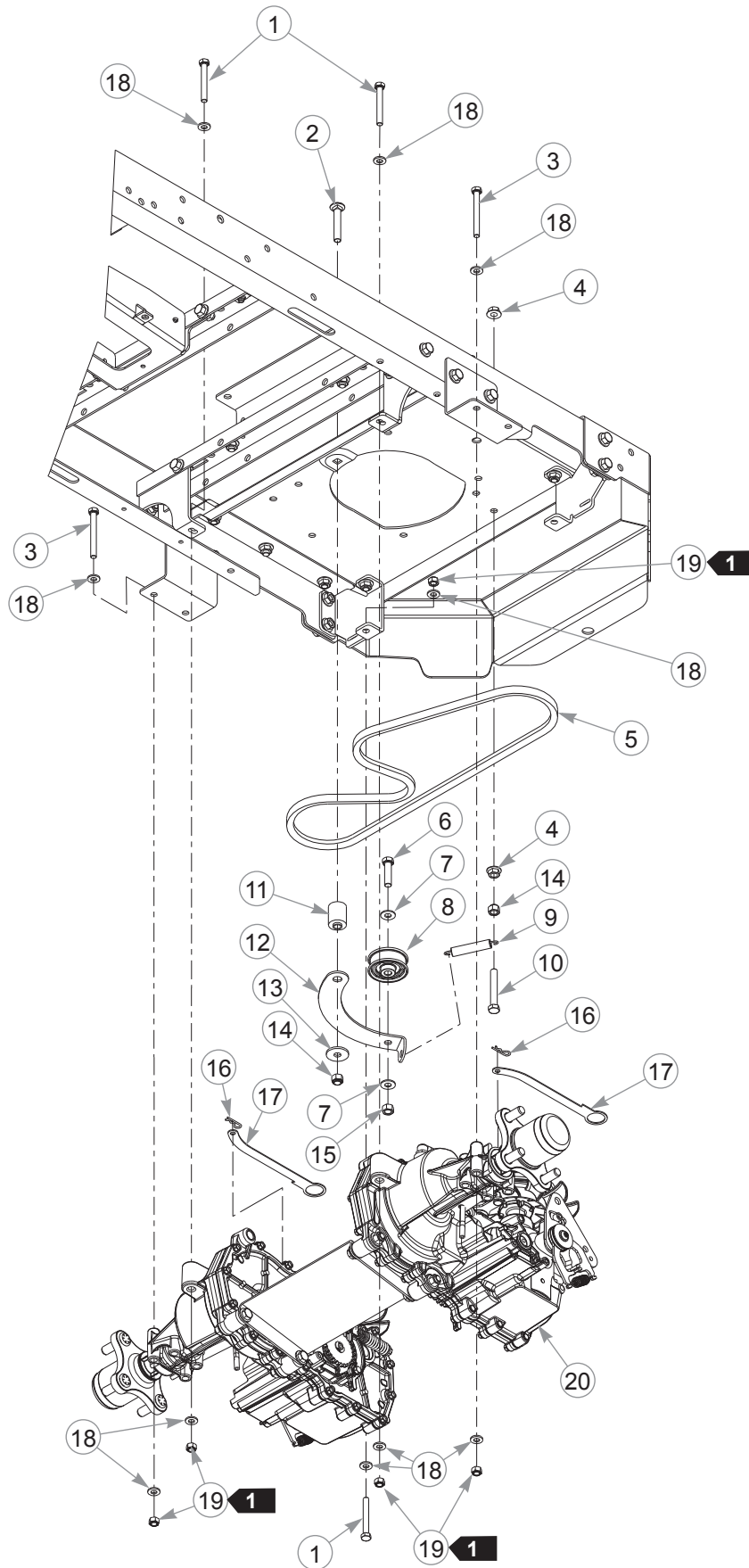

Hydraulic System

INDEX NO.	PART NO.	QTY.	DESCRIPTION
1	710087	4	CS .312-18 X 2.50 HX G5
2	604343	1	CB .375-16 X 2.25 STD ZN
3	043067	4	CS .312-18 X 3.00 HX G5 Z
4	016899	2	NT .375-16 HX FLK G5
5	603907	1	DRIVE BELT
6	080655	1	CS .375-16 X 1.50 HX G5
7	767954	2	FW .379 X .813 X .063
8	604491	1	PULLEY 2.0" IDLER
9	604490	1	SPRING
10	604487	1	CS .375-16 X 2.5 FULTH
11	116289	1	IDLER SPACER
12	116287	1	IDLER ARM
13	712893	1	FW .406 X 1.25 X .12 HRD Z
14	086660	2	NT .375-16 HX ZY NL
15	054502	1	NT .375-16 HX G5 ZNY
16	706549	2	HP .080D X 1.19
17	116218	2	TOW VALVE LINK
18	768523	16	FW .343 X .687 X .051/.080H
19	058776	8	NT 0.312-18 NL G5
20	N/A	1	TRANSMISSION ASSEMBLY

NOTES:

1. Torque to 23 N•m.

Transmission Assembly

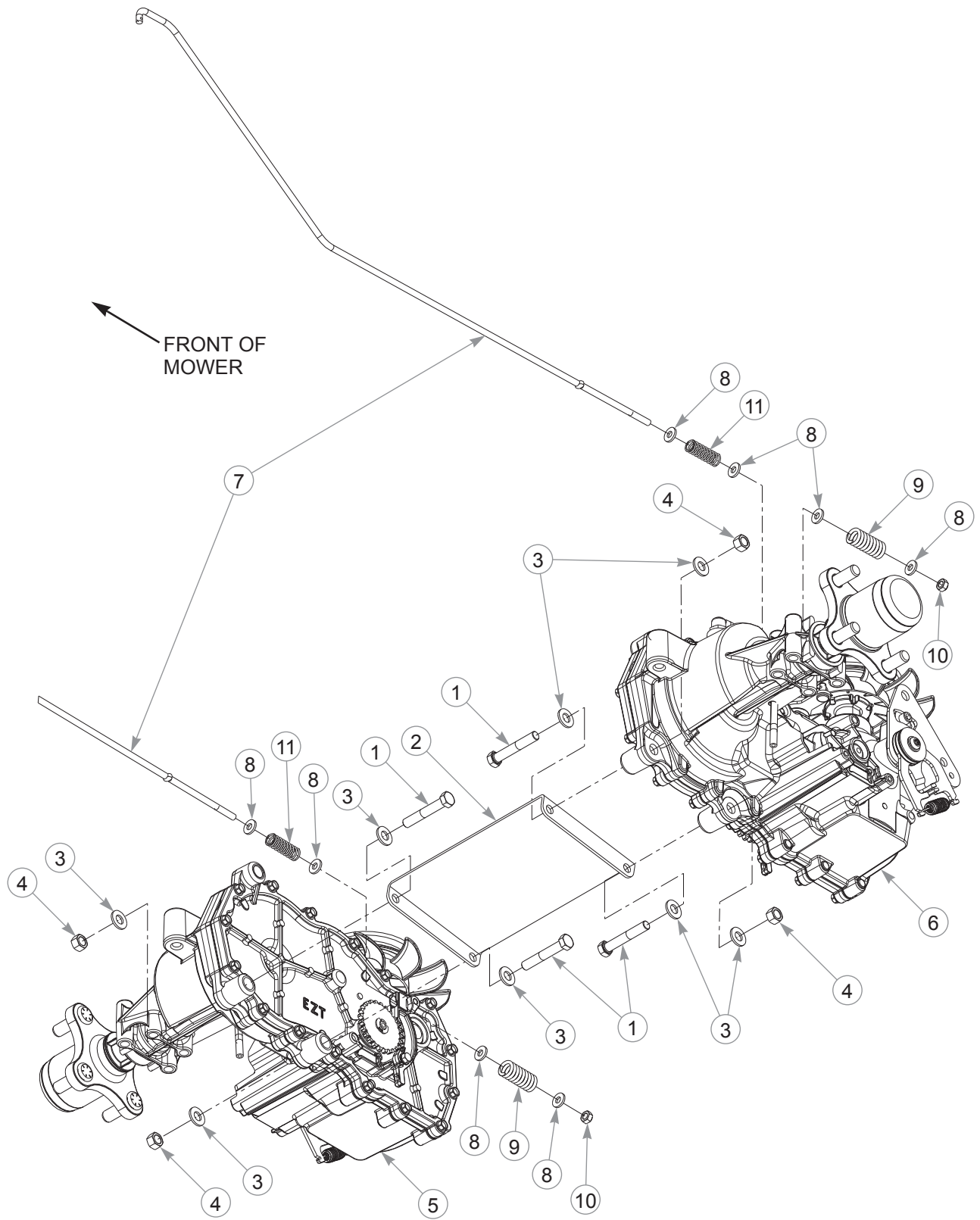

Transmission Assembly

INDEX NO.	PART NO.	QTY.	DESCRIPTION
1	056036	4	CS .375-16 X 2.25 HX G5
2	110042	1	HYDROSTAT CROSS BRACE
3	767954	8	FW .379 X .813 X .063
4	054502	4	NT .375-16 HX G5 ZNY
5	604127	1	RS TRANSMISSION
6	604128	1	LS TRANSMISSION
7	116143	2	ACTUATOR
8	768515	8	FW .281 X .625 X .066
9	601051	2	OVERTRAVEL SPRING
10	068551	2	NT .250-20 HX ZY NL
11	601131	2	SPRING

NOTES:

Transmission Service Parts

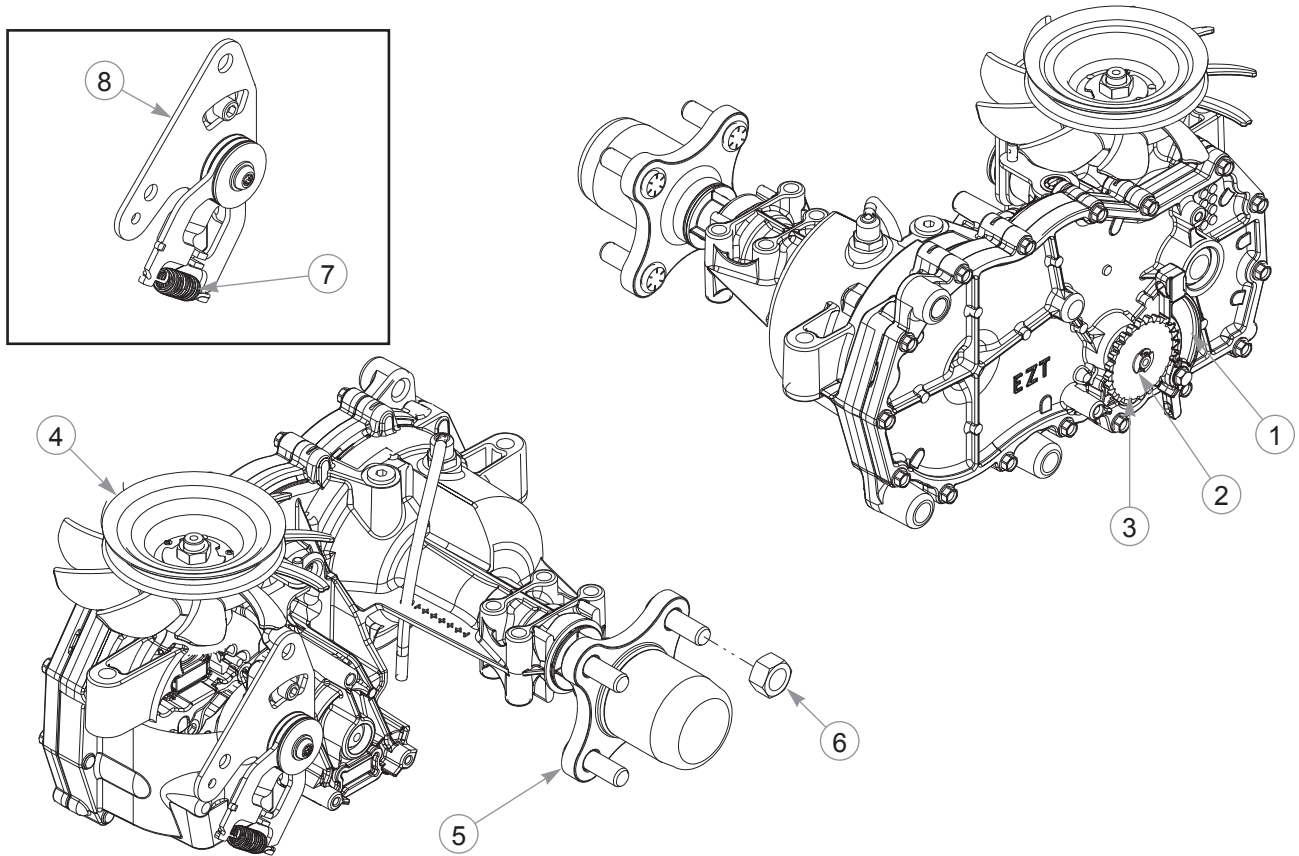

604127 RIGHT SIDE TRANSMISSION

INDEX NO.	PART NO.	QTY.	DESCRIPTION
1	795047	1	PARKING PAWL KIT
2	798371	1	RETAINING RING
3	798363	1	PARK BRAKE GEAR
4	602094	1	FAN/PULLEY KIT
5	601433	1	4 BOLT HUB KIT (WITH NUT)
6	788877	1	HUB NUT
7	604903	1	HG RTN SPRING
8	604901	1	HG RTN CW

604128 LEFT SIDE TRANSMISSION

INDEX NO.	PART NO.	QTY.	DESCRIPTION
1	795047	1	PARKING PAWL KIT
2	798371	1	RETAINING RING
3	798363	1	PARK BRAKE GEAR
4	602094	1	FAN/PULLEY KIT
5	601433	1	4 BOLT HUB KIT (WITH NUT)
6	788877	1	HUB NUT
7	604903	1	HG RTN SPRING
8	604902	1	HG RTN CCW

This page intentionally left blank.

Steering & Brake

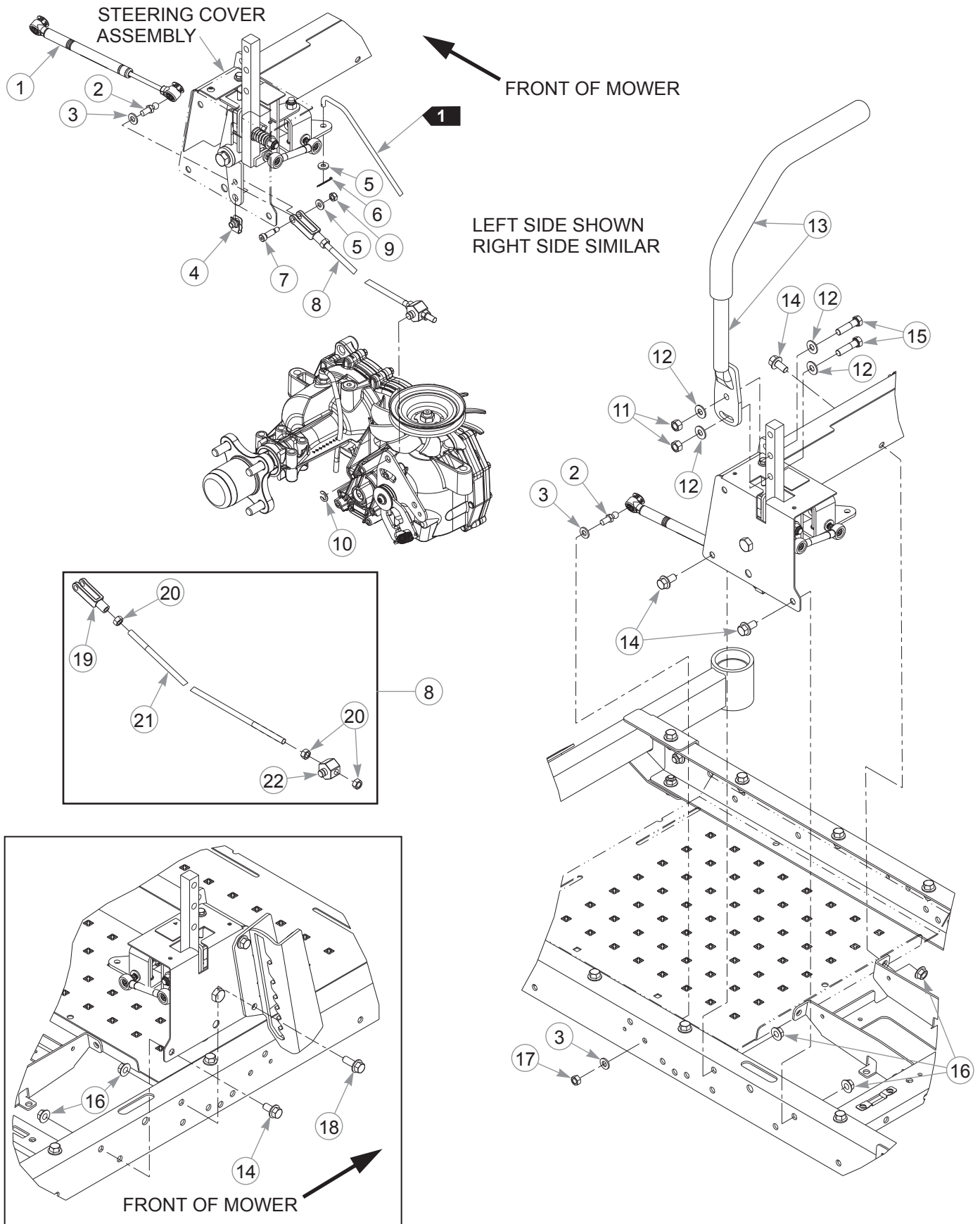

Steering & Brake

INDEX NO.	PART NO.	QTY.	DESCRIPTION
1	603983	2	DAMPER
2	781922	4	BALL STUD
3	768523	6	FW .343 X .687 X .051/.080H
4	601069	2	CN .312-18 X .20 MAX THK
5	768515	4	FW .281 X .625 X .066
6	048553	2	CP .062D X 1.00 LG HML Z
7	772483	2	SB .312 X .75 SH .250-20
8	605273	2	STEERING ROD ASSEMBLY
9	068551	2	NT .250-20 HX ZY NL
10	603332	2	CLIP
11	054502	4	NT .375-16 HX G5 ZNY
12	767954	8	FW .379 X .813 X .063
13	110370	2	STEERING BAR (WITH GRIP)
	781260	1	STEERING BAR GRIP
14	029629	5	CS .375-16 X .75 HX FLK
15	080655	4	CS .375-16 X 1.50 HX G5
16	016899	6	NT .375-16 HX FLK G5
17	034272	2	NT .312-18 HX G5
18	029751	1	CS .375-16 X 1.00 HXFLK
19	604173	2	YOKE, 5/16-24
20	041152	6	NT .312-24 HX ZNYC
21	603905	2	STEERING ROD
22	116144	2	STEERING BUSHING

NOTES:

1. Part of the Transmission Assembly.

Steering Cover Assembly

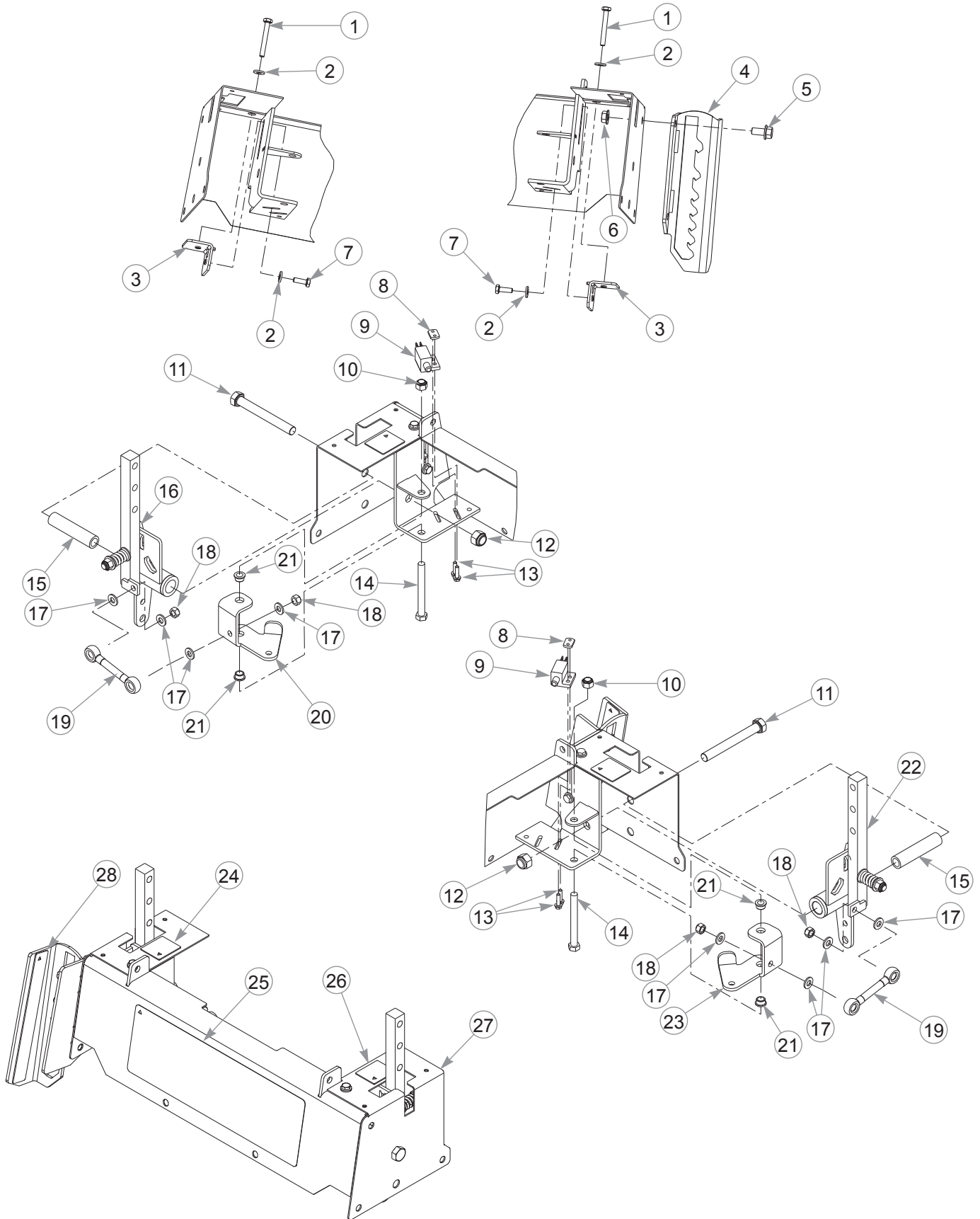

Steering Cover Assembly

INDEX NO.	PART NO.	QTY.	DESCRIPTION
1	604452	2	CS .250-20 X 2.00 HX FLTHD
2	768515	4	FW .281 X .625 X .066
3	605529	2	DRIVE STRAIGHT STOP
4	551912	1	LATCH WITH DECAL
5	029629	1	CS .375-16 X .75 HX FLK
6	016899	1	NT .375-16 HX FLK G5
7	055939	2	CS .250-20 X .75 HX G5
8	601822	2	NUT PLATE .420 CENTERS
9	781211	2	PUSH BUTTON SWITCH
10	086660	2	NT .375-16 HX NL G5
11	781708	2	CS .500-13 X 4.25 HX G5
12	781567	2	NT .500-13 NL G5
13	063198	4	CS 10-24 X .75 HX FLK ZN
14	005108	2	CS .375-16 X 3.50 HX G5 Z
15	604288	2	STEERING SPACER
16	604300	1	LS STEERING BOX
17	768523	8	FW .343 X .687 X .051/.080H
18	058776	4	NT .312-18 HX ZY NL
19	604179	2	BRAKE ROD
20	116142	1	LS BRAKE BELLCRANK
21	765339	4	BUSHING
22	604299	1	RS STEERING BOX
23	116141	1	RS BRAKE BELLCRANK
24	785220	1	RS STEERING DECAL
25	604195	1	RAPTOR ID DECAL
26	785139	1	LS STEERING DECAL
27	551698	1	STEERING COVER
28	604275	1	DECK HEIGHT DECAL

NOTES:

Section 4

Wheel & Tire—36" Mowers	4-2
Wheel & Tire—42" Mowers	4-4
Front Wheel Breakdown	4-6
Drive Wheel Breakdown—36" Mowers	4-8
Drive Wheel Breakdown—42" Mowers	4-9

Wheel & Tire—36" Mowers

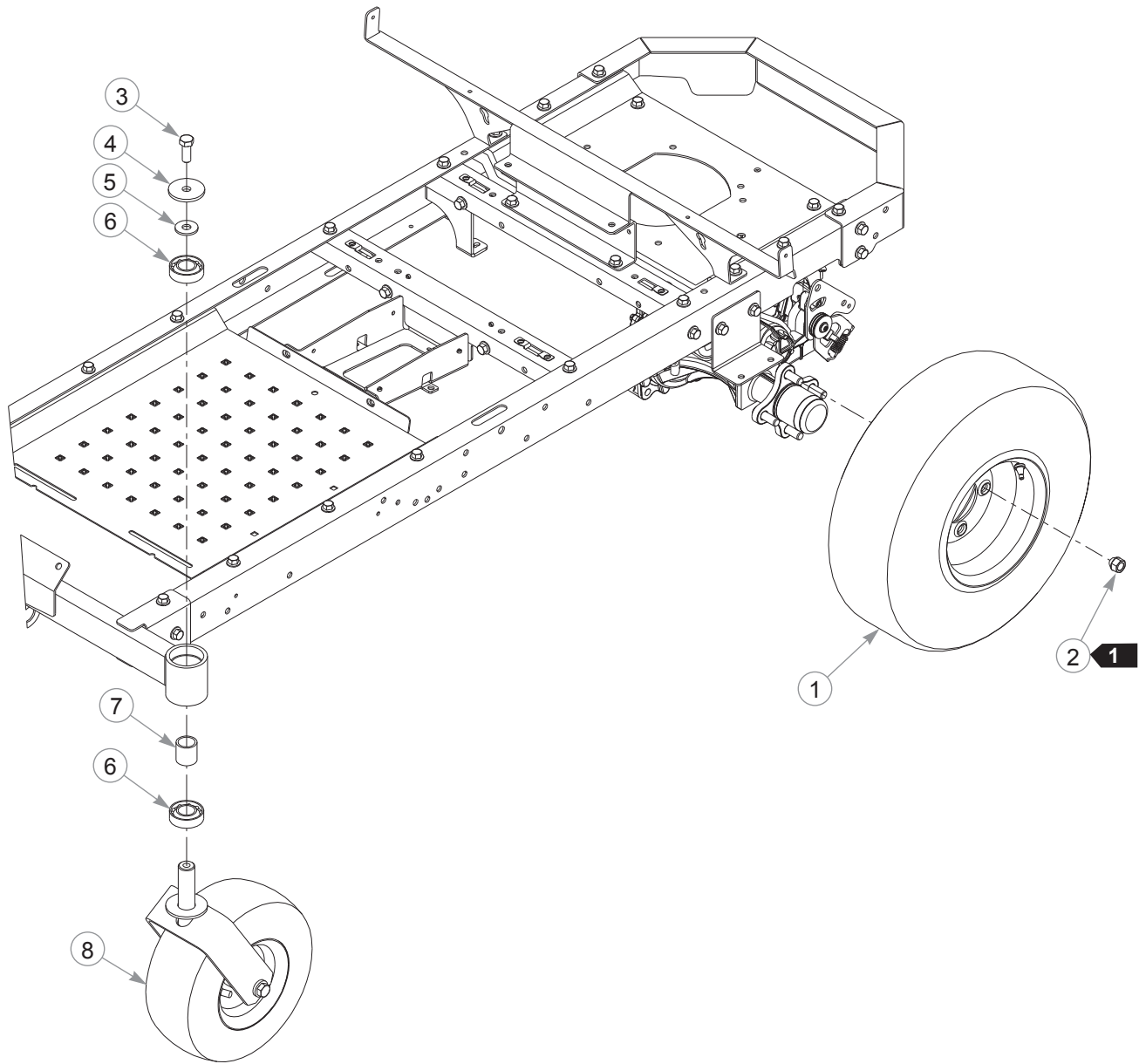

Wheel & Tire—36" Mowers

INDEX NO.	PART NO.	QTY.	DESCRIPTION
1	605261	2	TIRE/WHEEL ASSEMBLY
2	061077	8	WHEEL NUT
3	705954	2	CS .500-13 X 1.25 HS G5
4	344267	2	FW .510 X 2.15 X .187 SPL
5	712976	2	FW .531 X 1.375 X .125
6	784223	4	BEARING
7	784603	2	SPACER
8	N/A	1	FRONT WHEEL SUB-ASSEMBLY

NOTES:

1. Torque to 88–102 N•m.

Wheel & Tire—42" Mowers

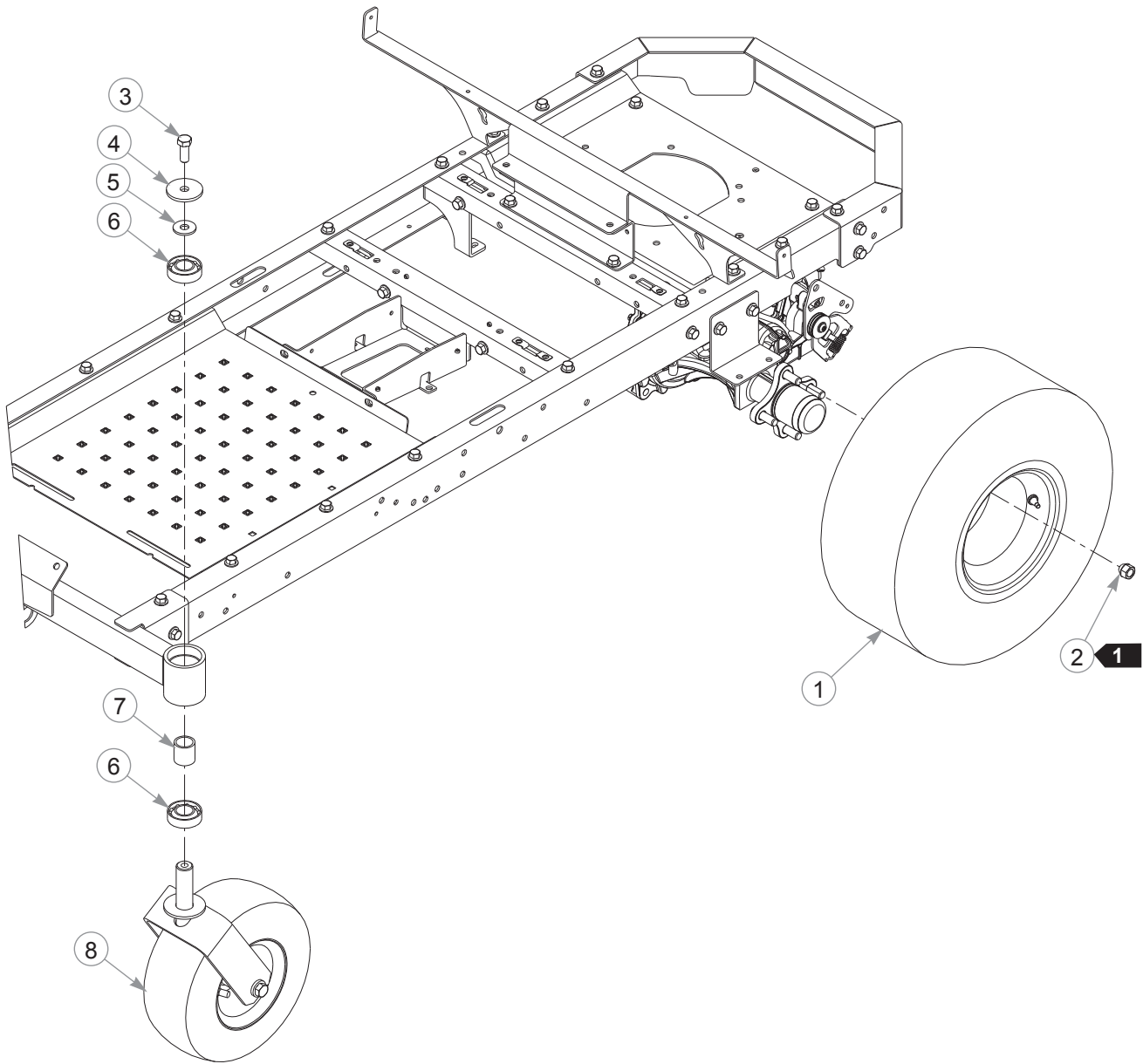

Wheel & Tire—42" Mowers

INDEX NO.	PART NO.	QTY.	DESCRIPTION
1	604013	2	TIRE/WHEEL ASSEMBLY
2	061077	8	WHEEL NUT
3	705954	2	CS .500-13 X 1.25 HS G5
4	344267	2	FW .510 X 2.15 X .187 SPL
5	712976	2	FW .531 X 1.75 X .125
6	784223	4	BEARING
7	784603	2	SPACER
8	N/A	1	FRONT WHEEL SUB-ASSEMBLY

NOTES:

1. Torque to 88–102 N•m.

Front Wheel Breakdown

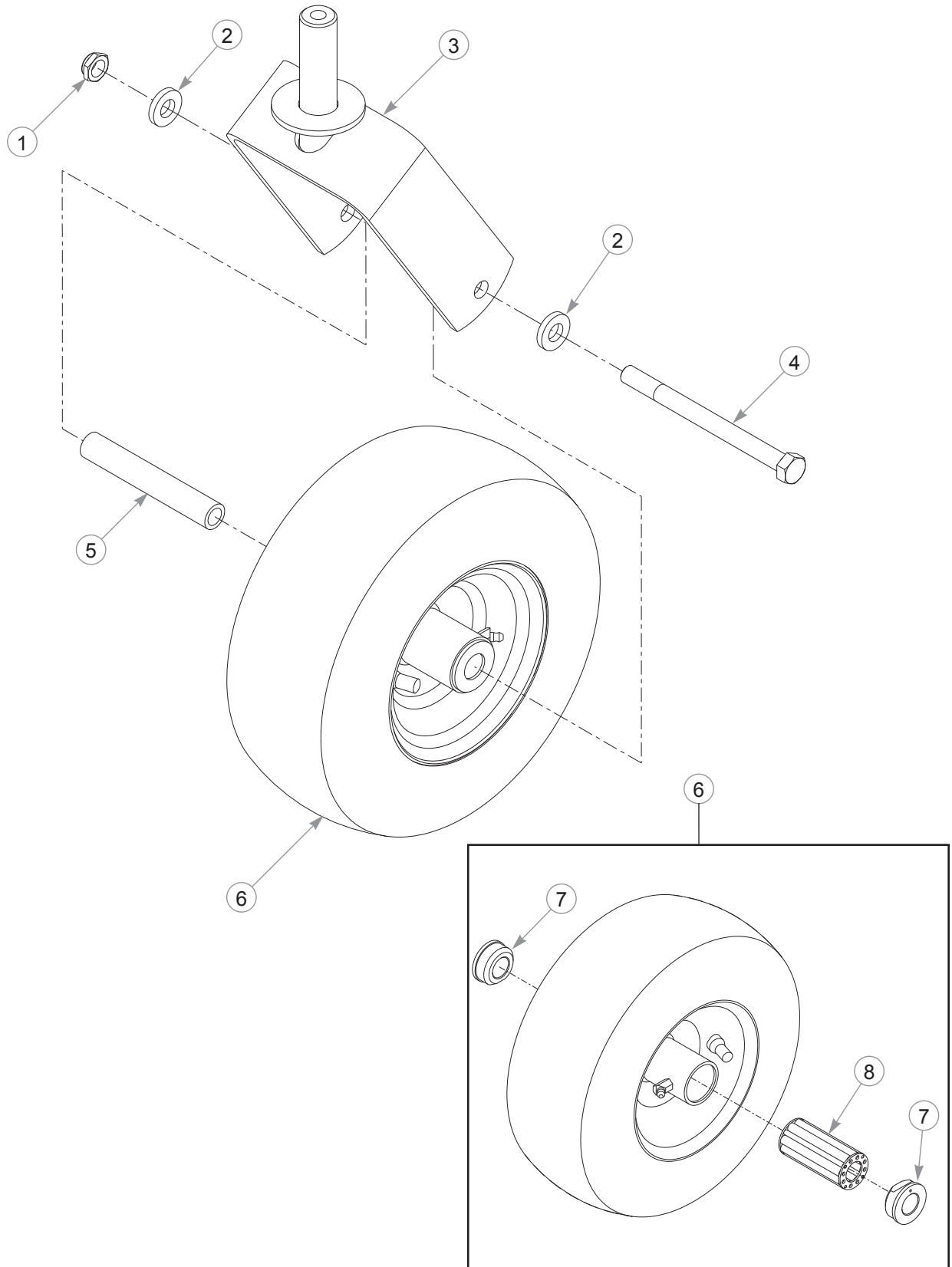

Front Wheel Breakdown

INDEX NO.	PART NO.	QTY.	DESCRIPTION
1	707398	1	NT .500-13 JAM NY LK
2	767962	2	FW .531 X 1.063 X .175
3	110116	1	CASTER FORK
4	604718	1	CS .500-13 X 6.00 HX G5
5	306969	1	GAUGE WHEEL SPACER
6	605113	1	TIRE/WHEEL ASSEMBLY 11 X 4-5 SMOOTH
	768044	1	TIRE/WHEEL ASSEMBLY 11 X 4-5 RIBBED
7	772806	2	BEARING CAP
8	772814	1	3/4" ROLLER BEARING

NOTES:

Drive Wheel Breakdown—36" Mowers

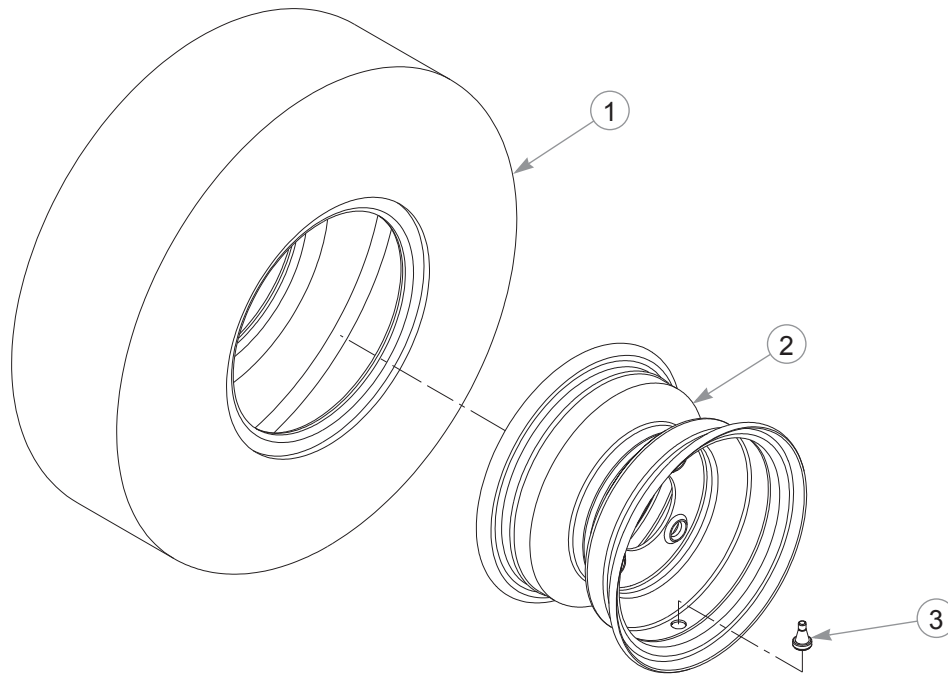

INDEX NO.	PART NO.	QTY	DESCRIPTION
1	605433	1	TIRE, 18 X 7.0-8
2	605262	1	WHEEL 8 X 6
3	019521	1	VALVE STEM

NOTES:

Drive Wheel Breakdown—42" Mowers

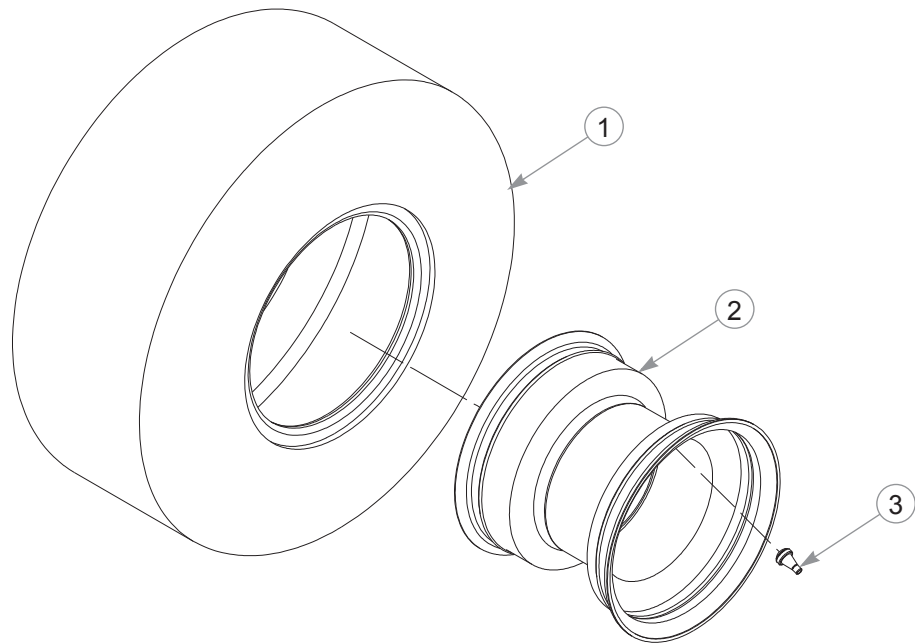

INDEX NO.	PART NO.	QTY	DESCRIPTION
1	604267	1	TIRE, 18 X 8.5-8
2	601820	1	WHEEL 8 X 6.93
3	019521	1	VALVE STEM

NOTES:

Section 5

Engine, Kawasaki	5-2
Engine Service Parts, Kawasaki	5-6
Fuel System.	5-8
Fuel Tank Service Parts	5-10

Engine, Kawasaki

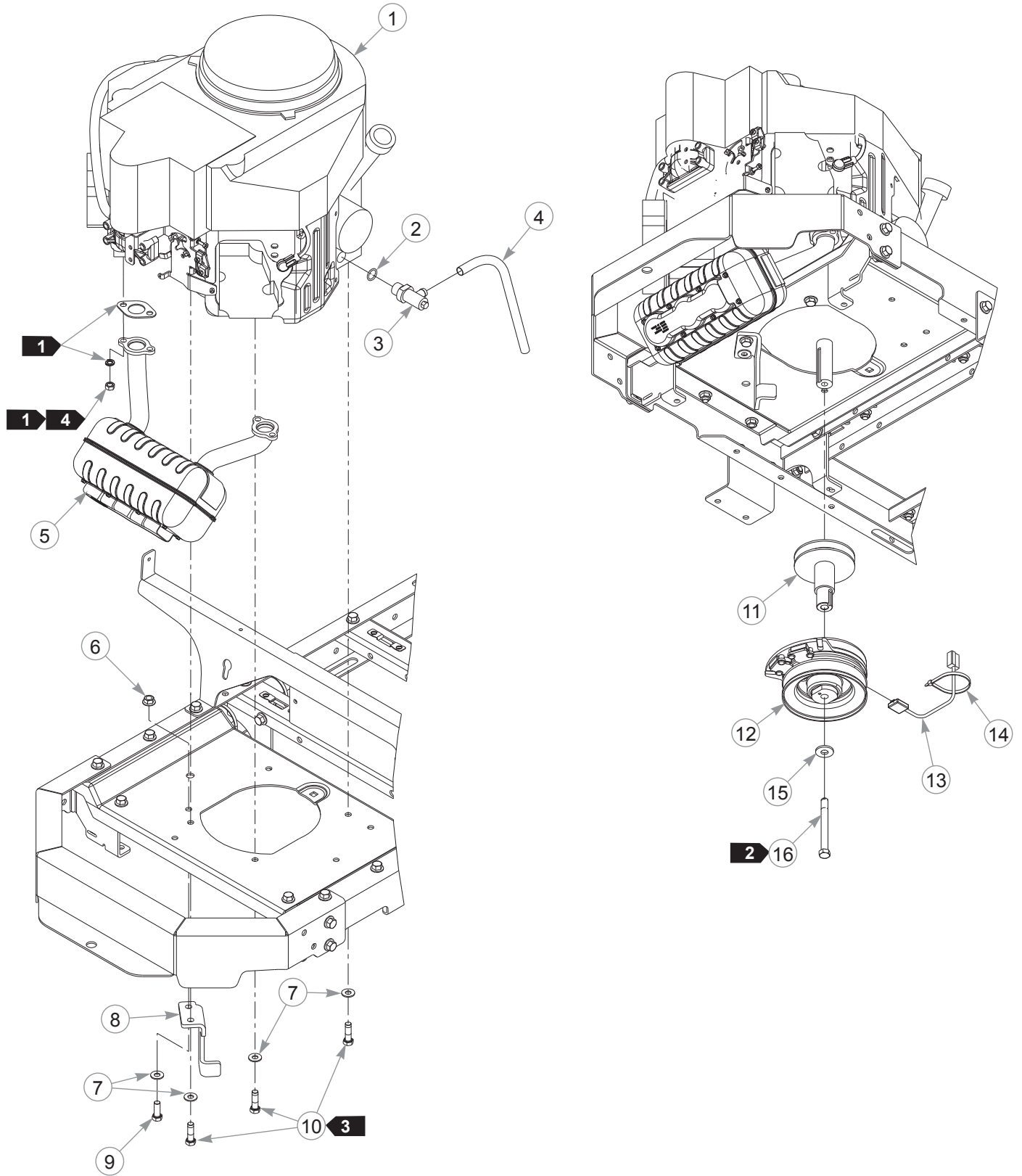

Engine, Kawasaki

INDEX NO.	PART NO.	QTY.	DESCRIPTION
1	N/A	1	KAWASAKI FR541V ENGINE
2	604369	1	O-RING
3	604350	1	OIL DRAIN VALVE
4	604463	31cm	OIL DRAIN HOSE
5	602999	1	MUFFLER
6	016899	1	NT .375-16 HX FLK G5
7	767954	5	FW .379 X .813 X .063
8	116290	1	CLUTCH ANCHOR
9	036244	1	CS .375-16 X 1.00 HX G5
10	602580	4	CS .375-16 X 1.25 HX G8 P85
11	604185	1	STUB SHAFT PUMP PULLEY
12	604244K	1	CLUTCH KIT
13	791251	1	CLUTCH HARNESS PIGTAIL
14	000331	3	WIRE TIE
15	602680	1	FW .453 X 1.12 X .119 HRD
16	604271	1	CS .437-20 X 4.00 HX G5

NOTES:

1. Supplied with the engine.
2. Torque the to 61–65 N•m. Replace (do not reuse) the cap screw if it is removed or loosened. Use only hand tools to install this fastener.
3. Torque to 41–47 N•m. Replace (do not reuse) the cap screw if it is removed or loosened. Use only hand tools to install this fastener.
4. Torque the nuts to 30 N•m.

Engine, Kawasaki

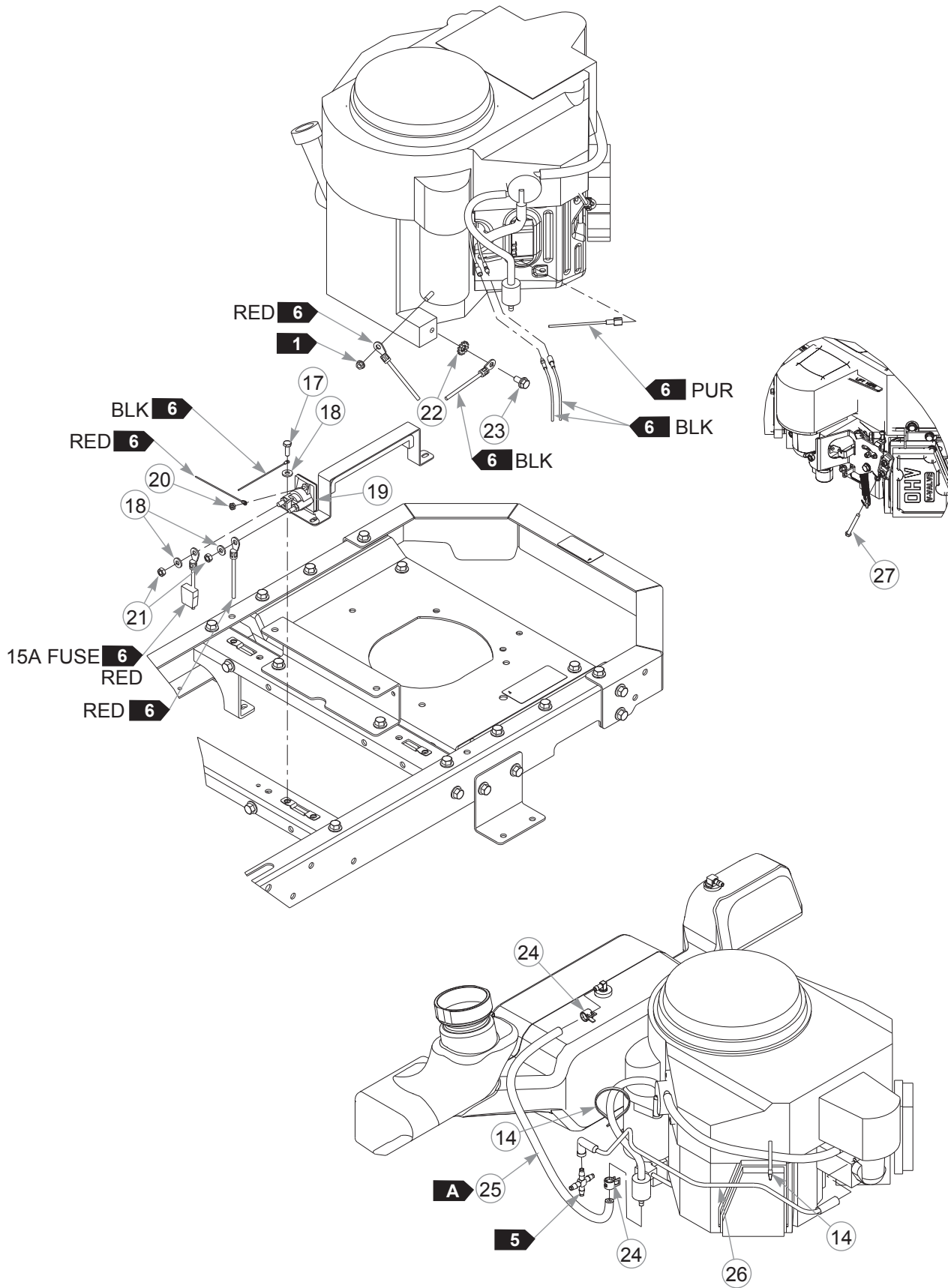

Engine, Kawasaki

INDEX NO.	PART NO.	QTY.	DESCRIPTION
17	055939	2	CS .250-20 X .75 HX G5
18	768515	4	FW .281 X .625 X .066
19	030817	1	STARTER SOLENOID
20	044255	1	NT #10-32 HX ZN
21	024927	2	NT .250-20 HX G5 ZNYC
22	029876	1	LW .312 INT-EXT TOOTH
23	720516	1	CS M8 X 1.25 X 16 HX FL 10.9
24	000323	2	HOSE CLAMP
25	015818	46 cm	1/4" FUEL LINE
26	604274	1	3/16" FORMED VAPOR LINE
27	603524	1	CS M5-0.8 X 50 MM DIN 933 (FUL TD)

NOTES:

FUEL LINE LENGTHS		
A	46 cm	TANK TO FUEL FILTER (FUEL)

5. Part of the fuel system.
6. Part of the wire harness.

Engine Service Parts, Kawasaki

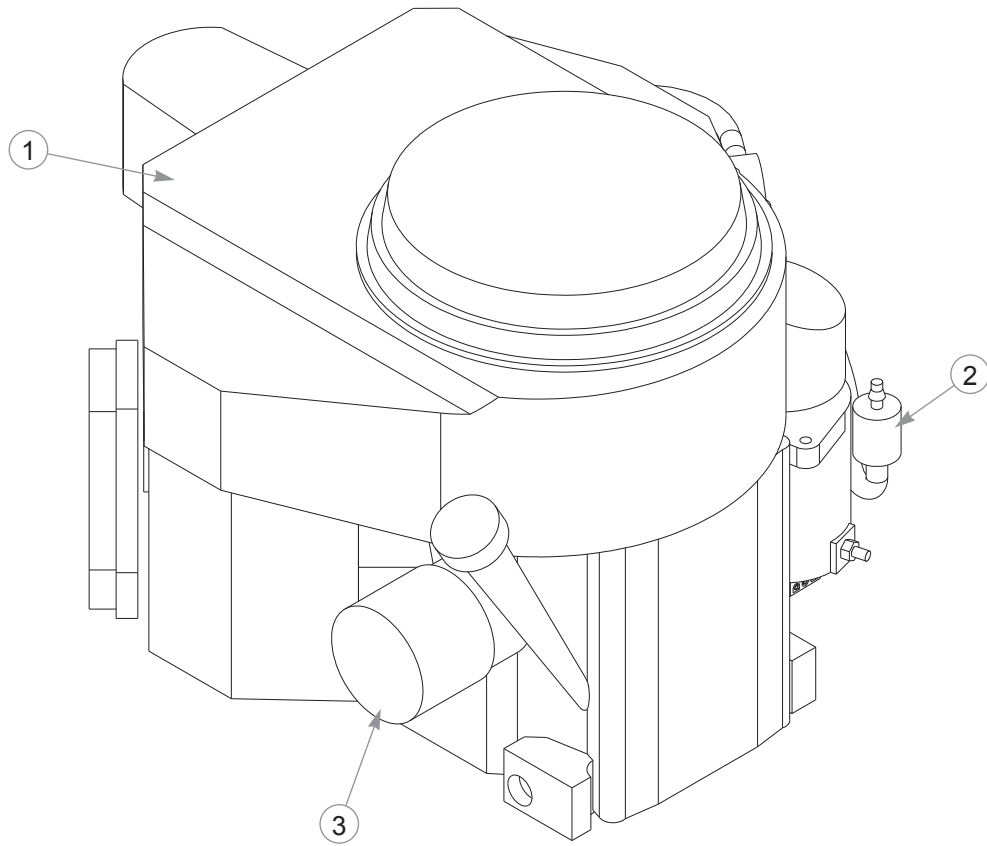

INDEX NO.	PART NO.	QTY	DESCRIPTION
1	604240	1	AIR FILTER
2	068478	1	IN-LINE FUEL FILTER
3	602581	1	OIL FILTER

NOTES:

This page intentionally left blank.

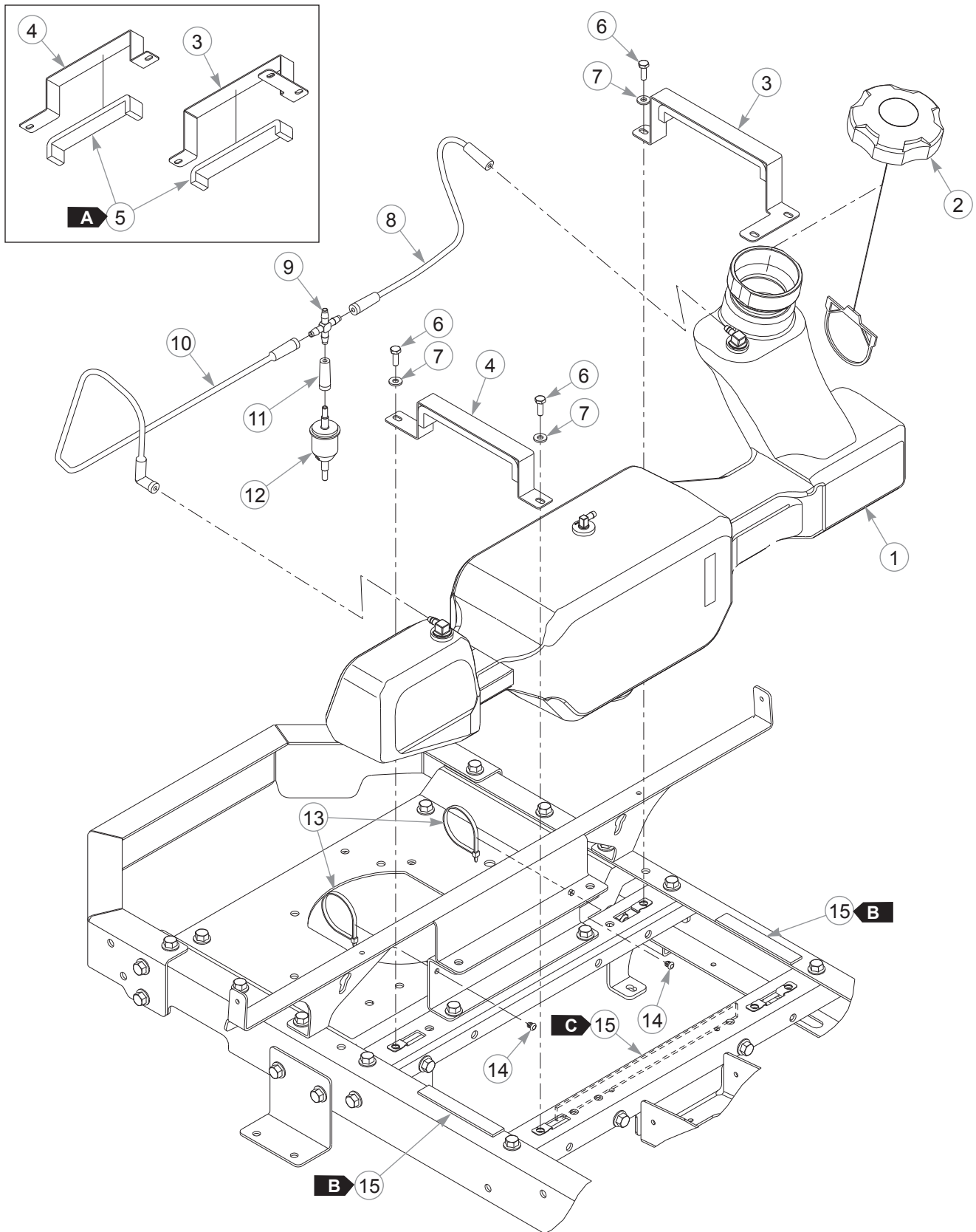

Fuel System



Fuel System

INDEX NO.	PART NO.	QTY.	DESCRIPTION
1	604336	1	FUEL TANK ASSEMBLY
2	603807	1	RATCHETING GAS CAP, 3.5"
3	117059	1	LEFT TANK MOUNT
4	117060	1	RIGHT TANK MOUNT
5	713198	47 cm	SEAL 3/8 X 3/4
6	055939	3	CS .250-20 X .75 HX G5
7	768515	3	FW .281 X .625 X .066
8	604279	1	3/16" FORMED VAPOR LINE
9	604322	1	1/4" HOSE BARB CROSS
10	604273	1	3/16" FORMED VAPOR LINE
11	604292	1	BOOT, 3/16" TO 1/4" BARB
12	604323	1	VAPOR SYSTEM FILTER
13	000331	2	WIRE TIE
14	604307	2	PUSH BUTTON MOUNT
15	033035	56 cm	WEATHERSTRIP

NOTES:

SEAL & WEATHERSTRIP LENGTH	
A 	23.5 cm
B 	13 cm
C 	30 cm

Fuel Tank Service Parts

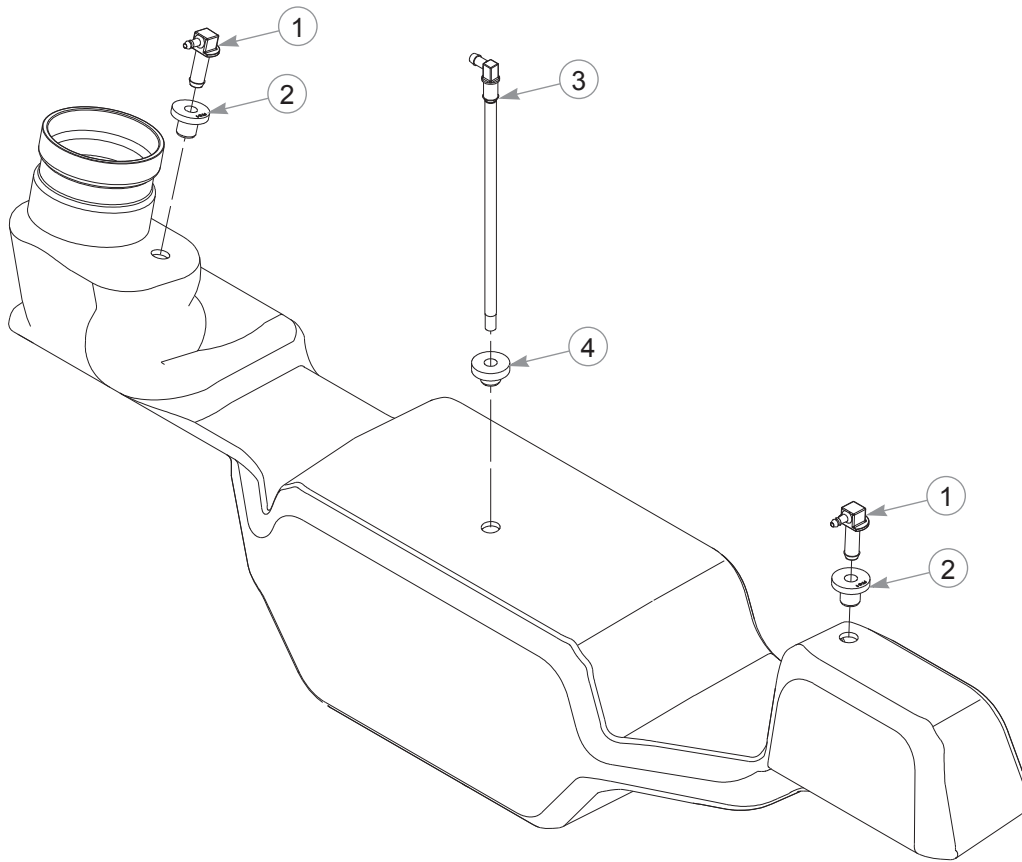

INDEX NO.	PART NO.	QTY.	DESCRIPTION
1	604199	2	VENT FITTING
2	604200	2	GROMMET
3	604340	1	SUCTION HOSE ASSEMBLY 7.75"
4	785295	1	GROMMET

NOTES:

Section 6

36" Service Deck	6-2
36" Deck Pulleys & Spindles	6-4
36" Deck	6-6
36" Guards.	6-8
42" Service Deck	6-10
42" Deck Pulleys & Spindles	6-12
42" Deck—S/N 14030001 & Higher.	6-14
42" Deck—S/N Prior to 14030001	6-16
42" Guards.	6-18
36"/42" Deck Lift	6-20

36" Service Deck

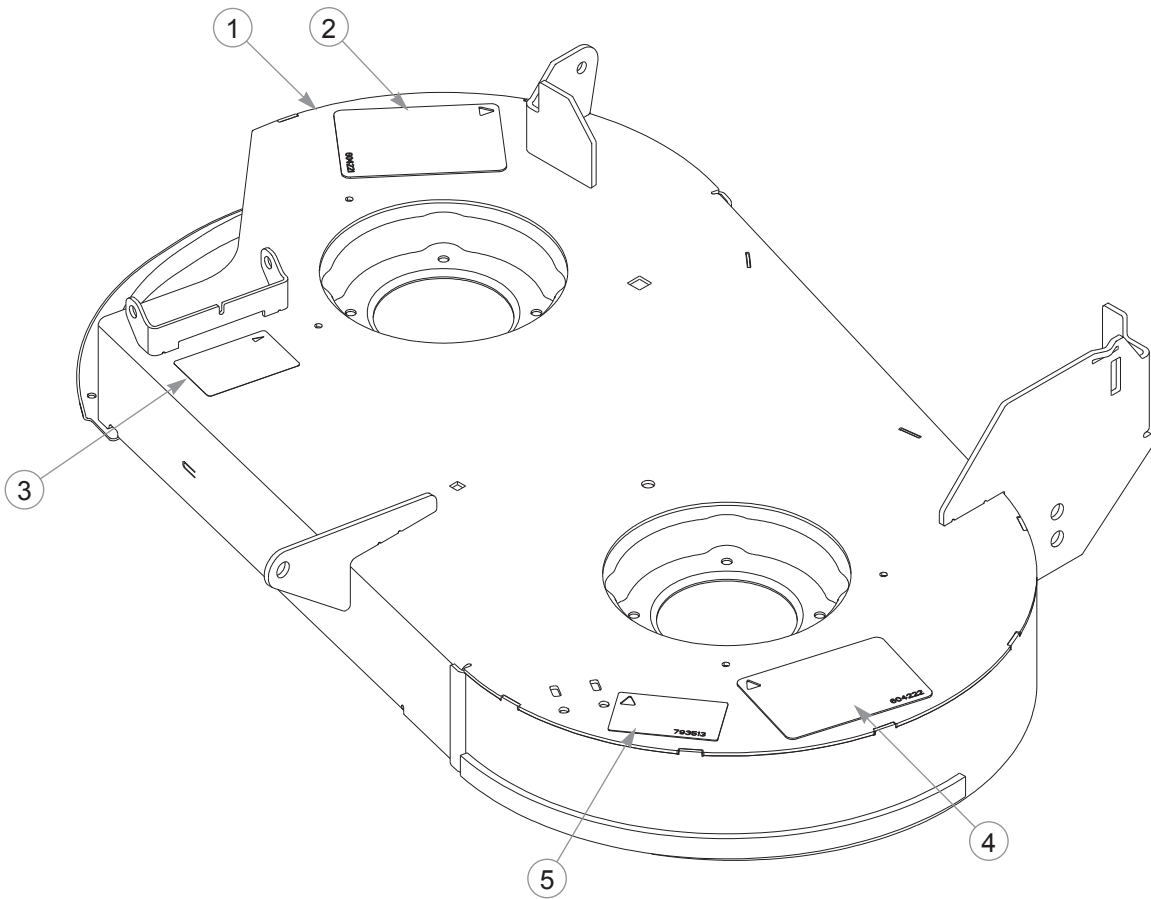

INDEX NO.	PART NO.	QTY.	DESCRIPTION
1	552705	1	36" DECK (WITH DECALS)
2	604221	1	DANGER/CHUTE DECAL
3	602243	1	BELT ROUTING DECAL
4	604222	1	DANGER/OBJECTS DECAL
5	793513	1	36" DECK ID DECAL

NOTES:

This page intentionally left blank.

36" Deck Pulleys & Spindles

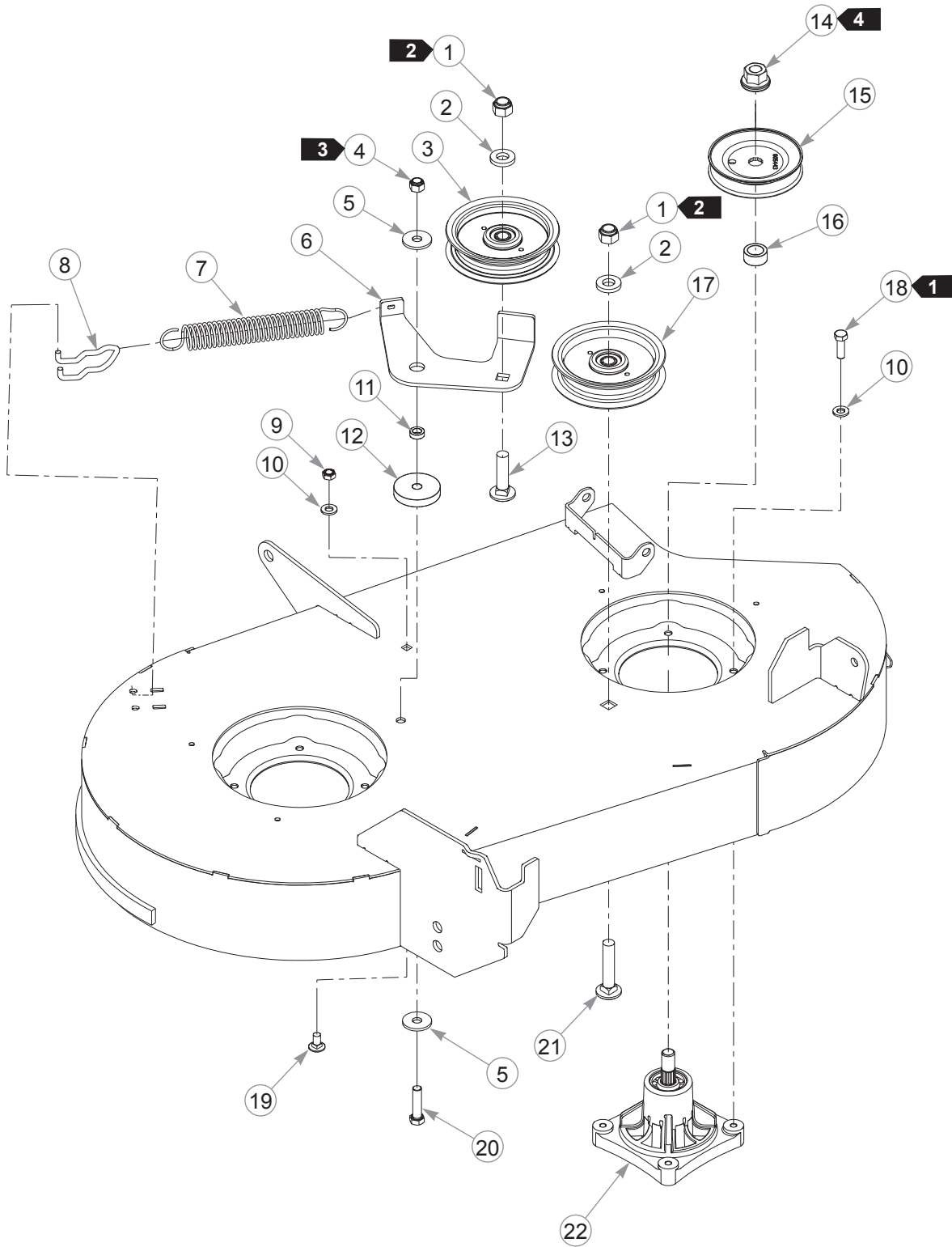

36" Deck Pulleys & Spindles

INDEX NO.	PART NO.	QTY.	DESCRIPTION
1	781567	2	NT .500-13 NL G5
2	767962	2	FW .531 X 1.063 X .175
3	603986	1	IDLER PULLEY, 4.00" FLAT
4	086660	1	NT .375-16 HX ZY NL
5	712893	2	FW .406 X 1.25 X .12 HRD Z
6	119936	1	36" PIVOTING IDLER ARM
7	605379	1	IDLER SPRING
8	604110	1	SPRING TENSIONER ANCHOR
9	604251	1	NT .312-18 HX NL JAM G2 ZN
10	768523	9	FW .343 X .687 X .051/.080H
11	601839	1	PIVOT SPACER BUSHING
12	117539	1	SPACER
13	604253	1	CB .50-13 X 2.00 STD ZN
14	604172	2	NT .562-18 HX G5 ZN
15	605443	2	DRIVE PULLEY "B-SEC"
16	604123	2	PULLEY SPACER
17	604219	1	IDLER PULLEY, 4.00" FLAT
18	036236	8	CS .312-18 X 1.00 HX G5
19	083147	1	CB .312-18 X .620 G5 ZN
20	080655	1	CS .375-16 X 1.50 HX G5
21	604254	1	CB .50-13 X 2.50 STD ZN
22	604214	2	SPINDLE ASSEMBLY

NOTES:

1. Torque to 24 N•m.
2. Torque to 99 N•m.
3. Torque to 41 N•m. The idler arm should pivot freely.
4. Torque to 68–102 N•m.

36" Deck

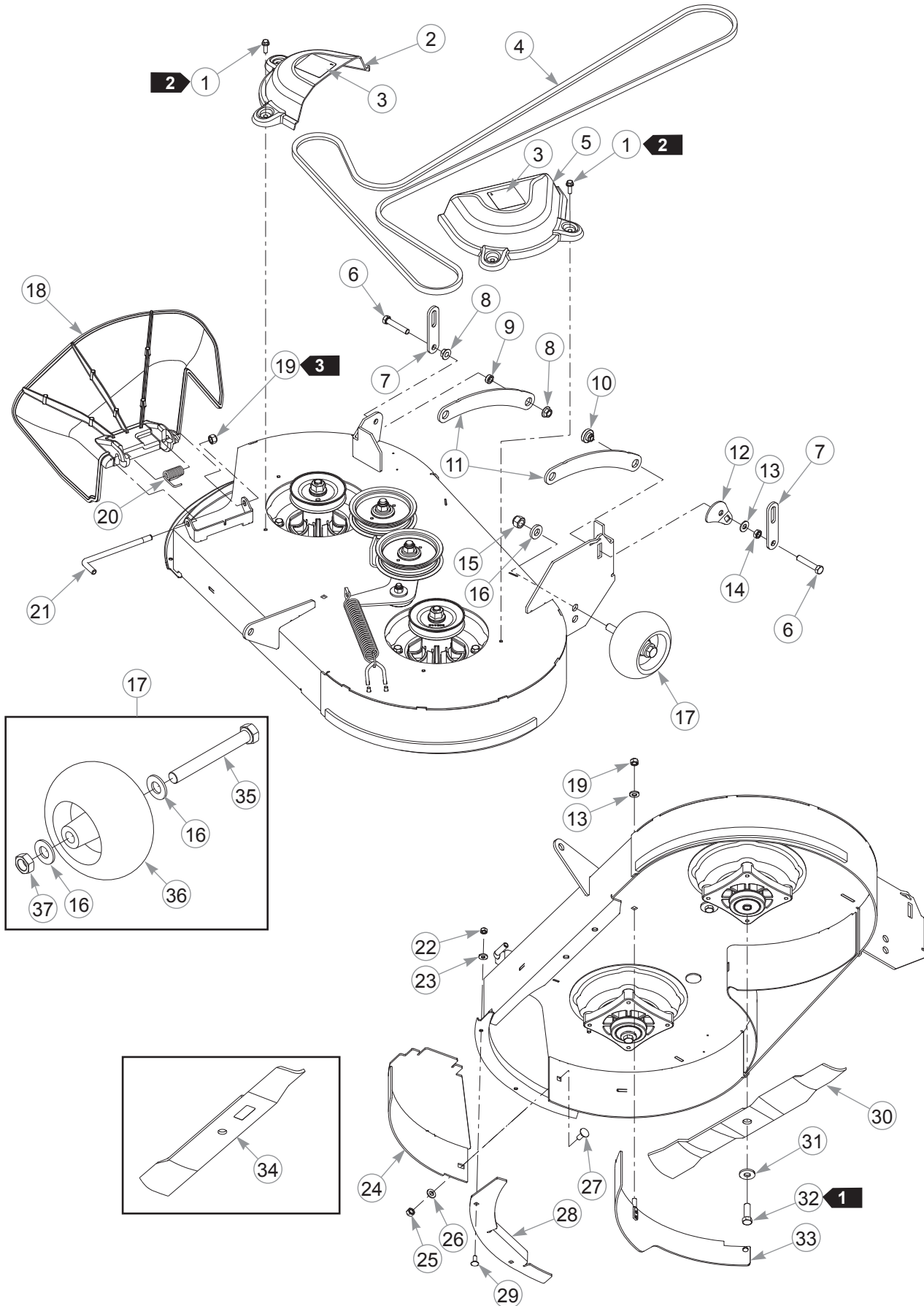

36" Deck

INDEX NO.	PART NO.	QTY.	DESCRIPTION
1	604324	4	CS .250-20 X .75 HX FLG
2	605254	1	RS PULLEY COVER
3	602562	2	NO SERVICE DECAL
4	771824	1	BELT, A 117" EL
5	604403	1	LS PULLEY COVER
6	016410	2	CS .375-16 X 2.00 HX G5
7	116157	2	DECK LIFT LINK
8	016899	2	NT .375-16 HX FLK G5
9	601839	1	PIVOT SPACER BUSHING
10	605016	1	DECK LEVELING NUT
11	116155	2	DECK LINK
12	116911	1	LEVELER CAM
13	768523	2	FW .343 X .687 X .051/.080H
14	706168	1	NT .375-16 HX JAM G5 Z
15	781567	1	NT .500-13 NL G5
16	767962	3	FW .531 X 1.063 X .175
17	788166	1	PLASTIC WHEEL ASSEMBLY (WITH HARDWARE)
18	604268	1	DISCHARGE CHUTE
19	058776	2	NT .312-18 HX ZY NL
20	604331	1	CHUTE SPRING
21	604346	1	DISCHARGE CHUTE PIN
22	068551	2	NT .250-20 HX ZY NL
23	768515	2	FW .281 X .625 X .066
24	117486	1	MULCH CLOSE OFF
25	058776	1	NT .312-18 HX ZY NL
26	768523	1	FW .343 X .687 X .051/.080H
27	016253	1	CB .312-18 X .75 FUL ZN
28	120526	1	TOE GUARD EXTENSION
29	601503	2	CB .250-20 X .625 ZNYC
30	794198	2	BLADE, 17.86"-MUL-F-CW
31	602680	2	FW .453 X 1.12 X .119 HRD
32	754101	2	CS .437-20 X 1.25 HX G5 ZNY
33	117478	1	MULCH WRAPPER
34	783753	2	BLADE, 17.86"-L-F-CW
	603995	2	BLADE, 17.86"-M-F-CW
	787721	2	BLADE, 17.86"-H-F-CW
	603848	2	BLADE, 17.86"-CAT-F-CW
	785436	2	BLADE, 17.86"-GAT-F-CW
35	781708	1	CS .500-13 X 4.25 HX G5
36	031997	1	PLASTIC WHEEL
37	053199	1	NT .500-13 HX JAM ZNYC

NOTES:

1. Torque to 65 N•m.
2. Torque to 3–7 N•m on these self-tapping screws.
3. Do not over-tighten. The discharge chute must pivot freely.

36" Guards

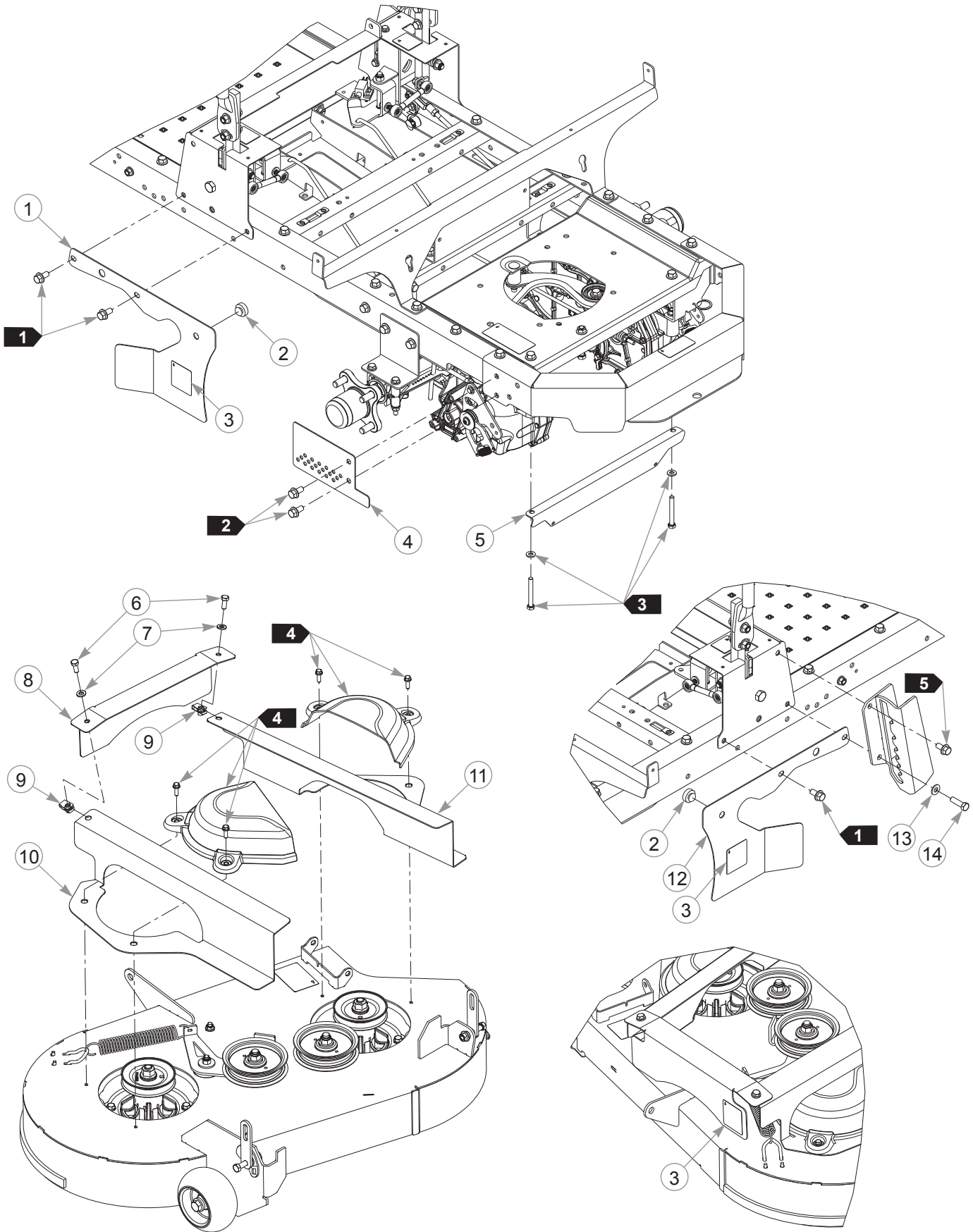

36" Guards

INDEX NO.	PART NO.	QTY.	DESCRIPTION
1	552975	1	LS BELT GUARD (WITH DECAL)
2	781880	2	BUMPER
3	602562	3	NO SERVICE DECAL
4	120855	2	TRANSMISSION GUARD
5	120838	1	CLUTCH GUARD
6	034280	2	CS .312-18 X .75 HX G5
7	768523	2	FW .343 X .687 X .051/.080H
8	552977	1	FRONT DECK GUARD (WITH DECAL)
9	601069	2	CN .312-18 X .20 MAX THK
10	121548	1	LS DECK GUARD
11	121549	1	RS DECK GUARD
12	552976	1	RS BELT GUARD (WITH DECAL)
13	767954	1	FW .379 X .813 X .063
14	052860	1	CS .375-16 X 1.25 HX G5 ZN

NOTES:

1. Part of the Steering Cover Assembly.
2. Part of the Frame.
3. Part of the Hydraulic System.
4. Part of the Deck.
5. Part of the Deck Lift.

42" Service Deck

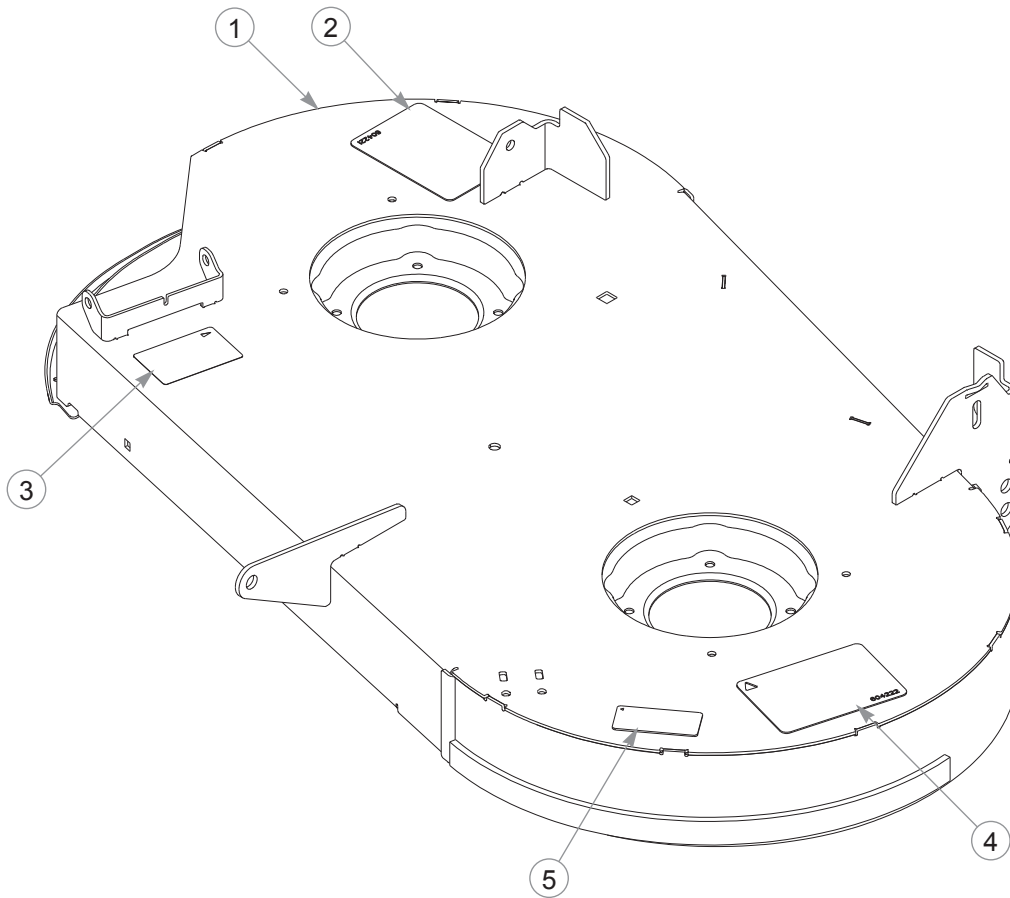

INDEX NO.	PART NO.	QTY.	DESCRIPTION
1	551896	1	42" DECK (WITH DECALS)
2	604221	1	DANGER/CHUTE DECAL
3	602243	1	BELT ROUTING DECAL
4	604222	1	DANGER/OBJECTS DECAL
5	793521	1	42" DECK ID DECAL

NOTES:

This page intentionally left blank.

42" Deck Pulleys & Spindles

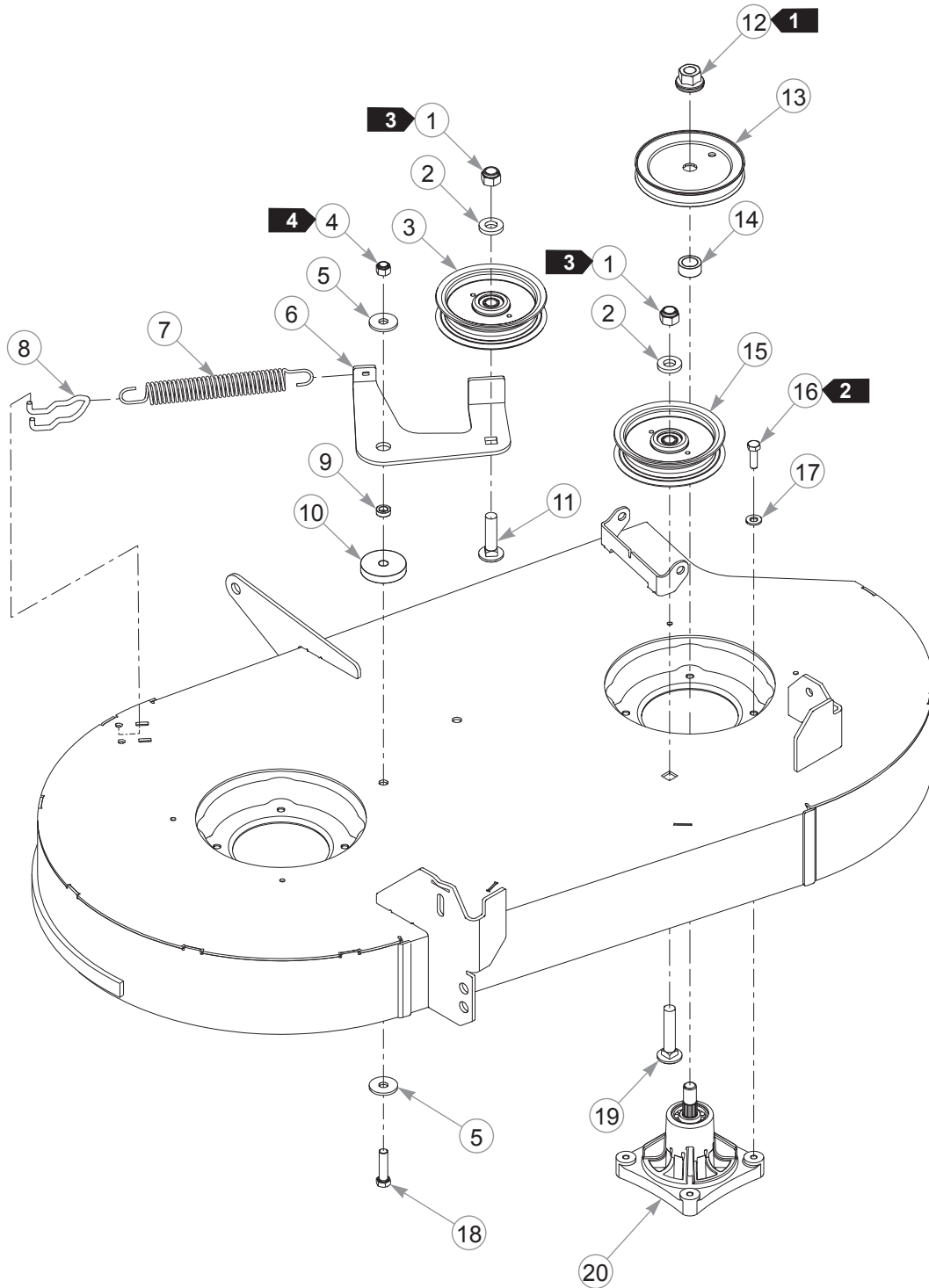

42" Deck Pulleys & Spindles

INDEX NO.	PART NO.	QTY.	DESCRIPTION
1	781567	2	NT .500-13 HX G8 ZY NL
2	767962	2	FW .531 X 1.063 X .175
3	603986	1	IDLER PULLEY, 4.00" FLAT
4	086660	1	NT .375-16 HX ZY NL
5	712893	2	FW .406 X 1.25 X .12 HRD Z
6	117512	1	IDLER ARM
7	604291	1	IDLER SPRING
8	604110	1	SPRING TENSIONER ANCHOR
9	601839	1	PIVOT SPACER BUSHING
10	117539	1	SPACER
11	604253	1	CB .50-13 X 2.00 STD ZN
12	604172	2	NT .562-18 HX G5 ZN
13	603987	2	PULLEY
14	604123	2	PULLEY SPACER
15	604219	1	IDLER PULLEY, 4.00" FLAT
16	036236	8	CS .312-18 X 1.00 HX G5
17	768523	8	FW .343 X .687 X .051/.080H
18	080655	1	CS .375-16 X 1.50 HX G5
19	604254	1	CB .50-13 X 2.50 STD ZN
20	604214	2	SPINDLE ASSEMBLY

NOTES:

1. Torque to 68–102 N•m.
2. Torque to 24 N•m.
3. Torque to 99 N•m.
4. Torque to 41 N•m. The idler arm should pivot freely.

42" Deck—S/N 14030001 & Higher

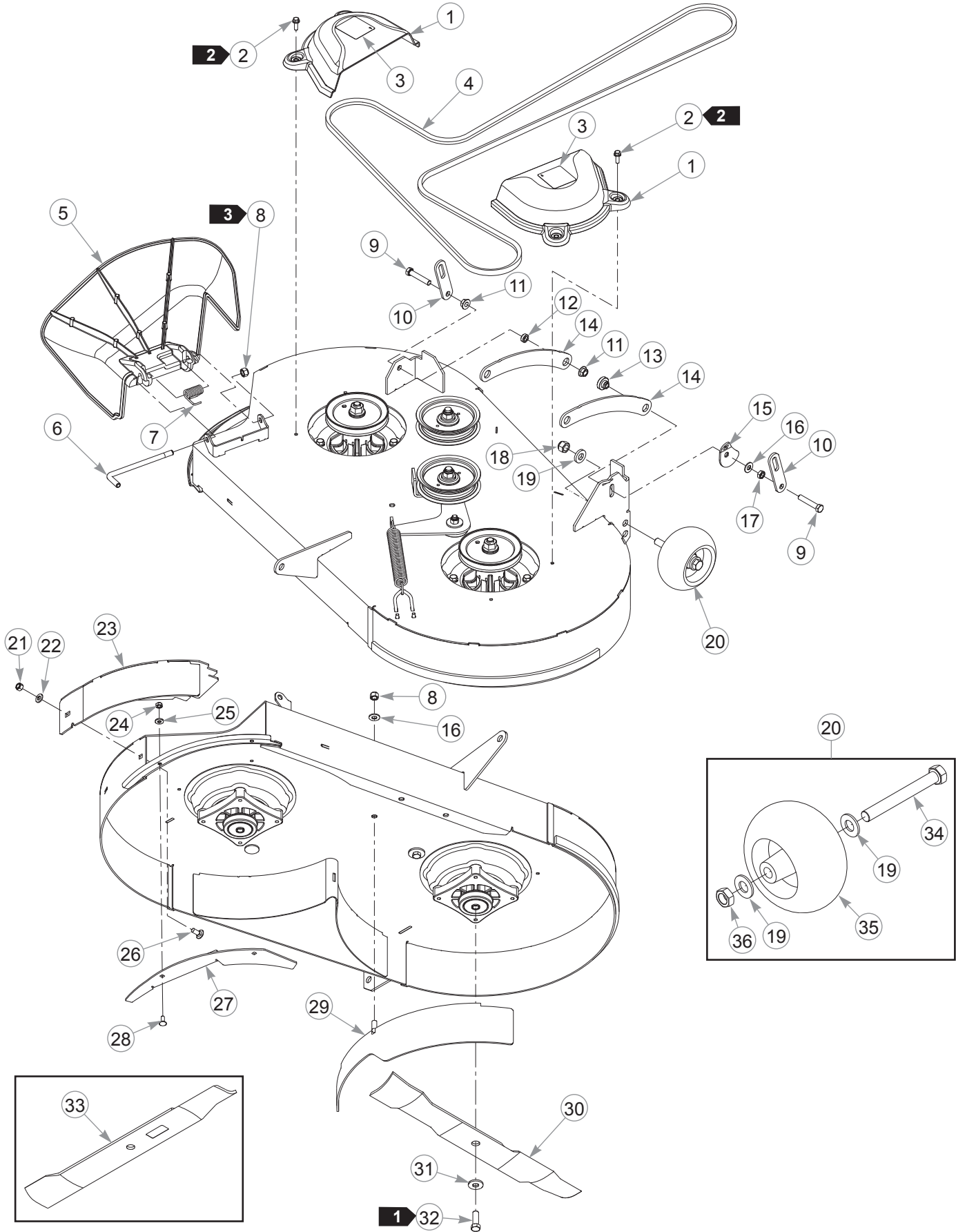

42" Deck—S/N 14030001 & Higher

INDEX NO.	PART NO.	QTY.	DESCRIPTION
1	552183	2	PULLEY COVER
2	604324	4	CS .250-20 X .75 HX FLG
3	602562	2	NO SERVICE DECAL
4	793828	1	BELT, A SEC
5	604268	1	DISCHARGE CHUTE
6	604346	1	DISCHARGE CHUTE PIN
7	604331	1	CHUTE SPRING
8	086660	2	NT .375-16 HX ZY NL
9	016410	2	CS .375-16 X 2.00 HX G5
10	116157	2	DECK LIFT LINK
11	016899	2	NT .375-16 HX FLK G5
12	601839	1	PIVOT SPACER BUSHING
13	605016	1	DECK LEVELING NUT
14	116155	2	DECK LINK
15	116911	1	LEVELER CAM
16	767954	2	FW .379 X .813 X .063
17	706168	1	NT .375-16 HX JAM G5 Z
18	781567	1	NT .500-13 HX G8 ZY NL
19	767962	3	FW .531 X 1.063 X .175
20	788166	1	PLASTIC WHEEL ASSEMBLY
21	058776	1	NT .312-18 HX ZY NL
22	768523	1	FW .343 X .687 X .051/.080H
23	117747	1	MULCH CLOSE OFF
24	068551	2	NT .250-20 HX ZY NL
25	768515	2	FW .281 X .625 X .066
26	016253	1	CB .312-18 X .75 FUL ZN
27	117663	1	TOE GUARD EXTENSION
28	601503	2	CB .250-20 X .625 ZNYC
29	109312	1	MULCH BAFFLE
30	794214	2	BLADE, 20.50"-MUL-F-CW
	603992	2	BLADE, 20.50"-M-F-CW
	794685	2	BLADE, F20.50"-H-F-CW
	793935	2	BLADE, 20.50"-CAT-F-CW
	794230	2	BLADE, 20.50" GAT-F-CW
31	602680	2	FW .453 X 1.12 X .119 HRD
32	754101	2	CS .437-20 X 1.25 HX G5 ZNY
33	793794	2	BLADE, 20.50"-L-F-CW
34	781708	1	CS .500-13 X 4.25 HX G5
35	031997	1	PLASTIC WHEEL
36	053199	1	NT .500-13 HX JAM ZNYC

NOTES:

1. Torque to 65 N•m.
2. Torque to 11 N•m on these 4 self-tapping screws.
3. Do not over-tighten. The discharge chute must pivot freely.

42" Deck—S/N Prior to 14030001

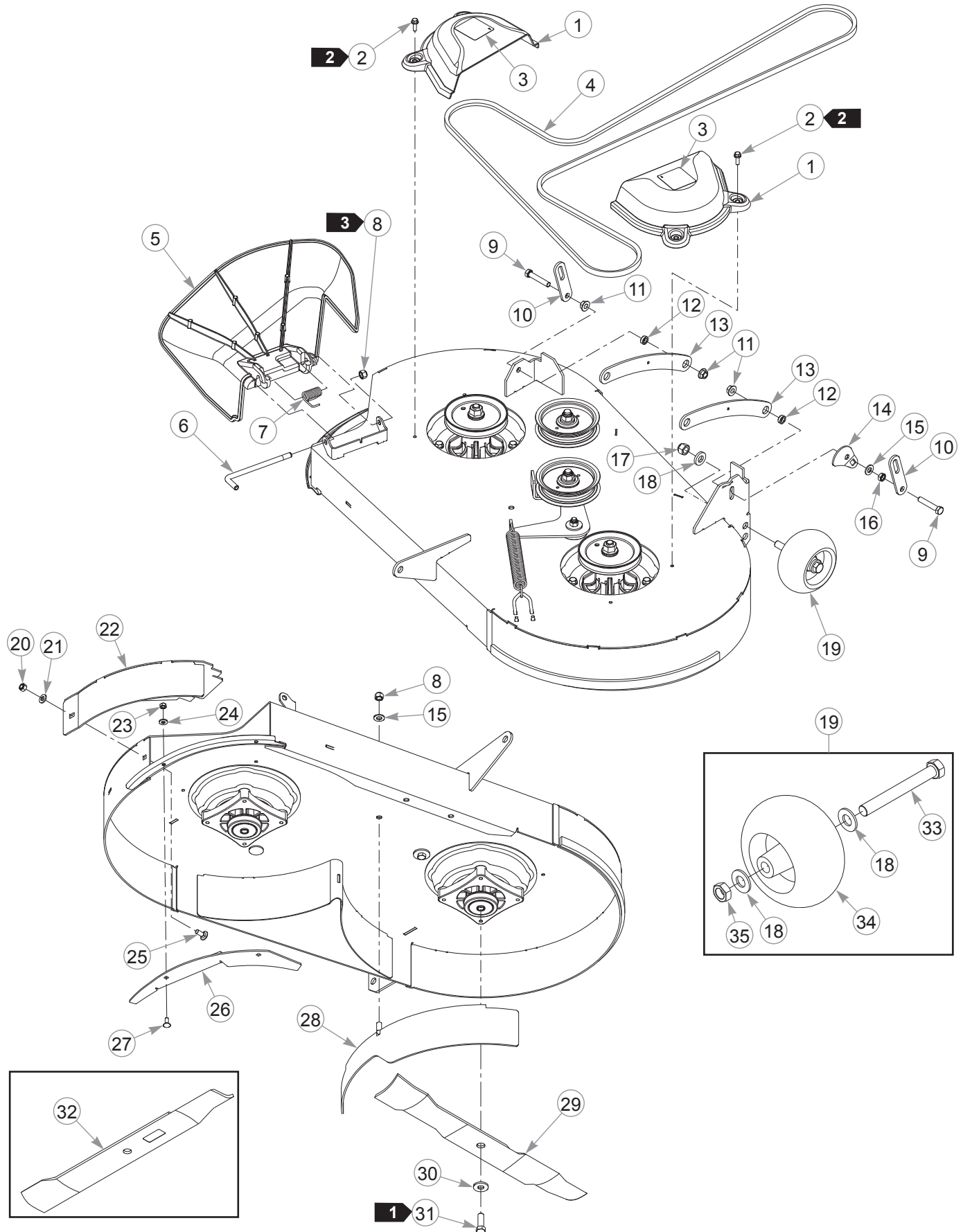

42" Deck—S/N Prior to 14030001

INDEX NO.	PART NO.	QTY.	DESCRIPTION
1	552183	2	RS PULLEY COVER
2	604324	4	CS .250-20 X .75 HX FLG
3	602562	2	NO SERVICE DECAL
4	793828	1	BELT, A SEC
5	604268	1	DISCHARGE CHUTE
6	604346	1	DISCHARGE CHUTE PIN
7	604331	1	CHUTE SPRING
8	086660	2	NT .375-16 HX ZY NL
9	016410	2	CS .375-16 X 2.00 HX G5
10	116157	2	DECK LIFT LINK
11	016899	3	NT .375-16 HX FLK G5
12	601839	2	PIVOT SPACER BUSHING
13	116155	2	DECK LINK
14	116911	1	LEVELER CAM
15	767954	2	FW .379 X .813 X .063
16	706168	1	NT .375-16 HX JAM G5 Z
17	781567	1	NT .500-13 HX G8 ZY NL
18	767962	1	FW .531 X 1.063 X .175
19	788166	1	PLASTIC WHEEL ASSEMBLY
20	058776	1	NT .312-18 HX ZY NL
21	768523	1	FW .343 X .687 X .051/.080H
22	117747	1	MULCH CLOSE OFF
23	068551	2	NT .250-20 HX ZY NL
24	768515	2	FW .281 X .625 X .066
25	016253	1	CB .312-18 X .75 FUL ZN
26	117663	1	TOE GUARD EXTENSION
27	601503	2	CB .250-20 X .625 ZNYC
28	109312	1	MULCH BAFFLE
29	794214	2	BLADE, 20.50"-MUL-F-CW
	603992	2	BLADE, 20.50"-M-F-CW
	794685	2	BLADE, F20.50"-H-F-CW
	793935	2	BLADE, 20.50"-CAT-F-CW
	794230	2	BLADE, 20.50" GAT-F-CW
30	602680	2	FW .453 X 1.12 X .119 HRD
31	754101	2	CS .437-20 X 1.25 HX G5 ZNY
32	793794	2	BLADE, 20.50"-L-F-CW
33	781708	1	CS .500-13 X 4.25 HX G5
34	031997	1	PLASTIC WHEEL
35	053199	1	NT .500-13 HX JAM ZNYC

NOTES:

1. Torque to 65 N•m.
2. Torque to 11 N•m on these 4 self-tapping screws.
3. Do not over-tighten. The discharge chute must pivot freely.

42" Guards

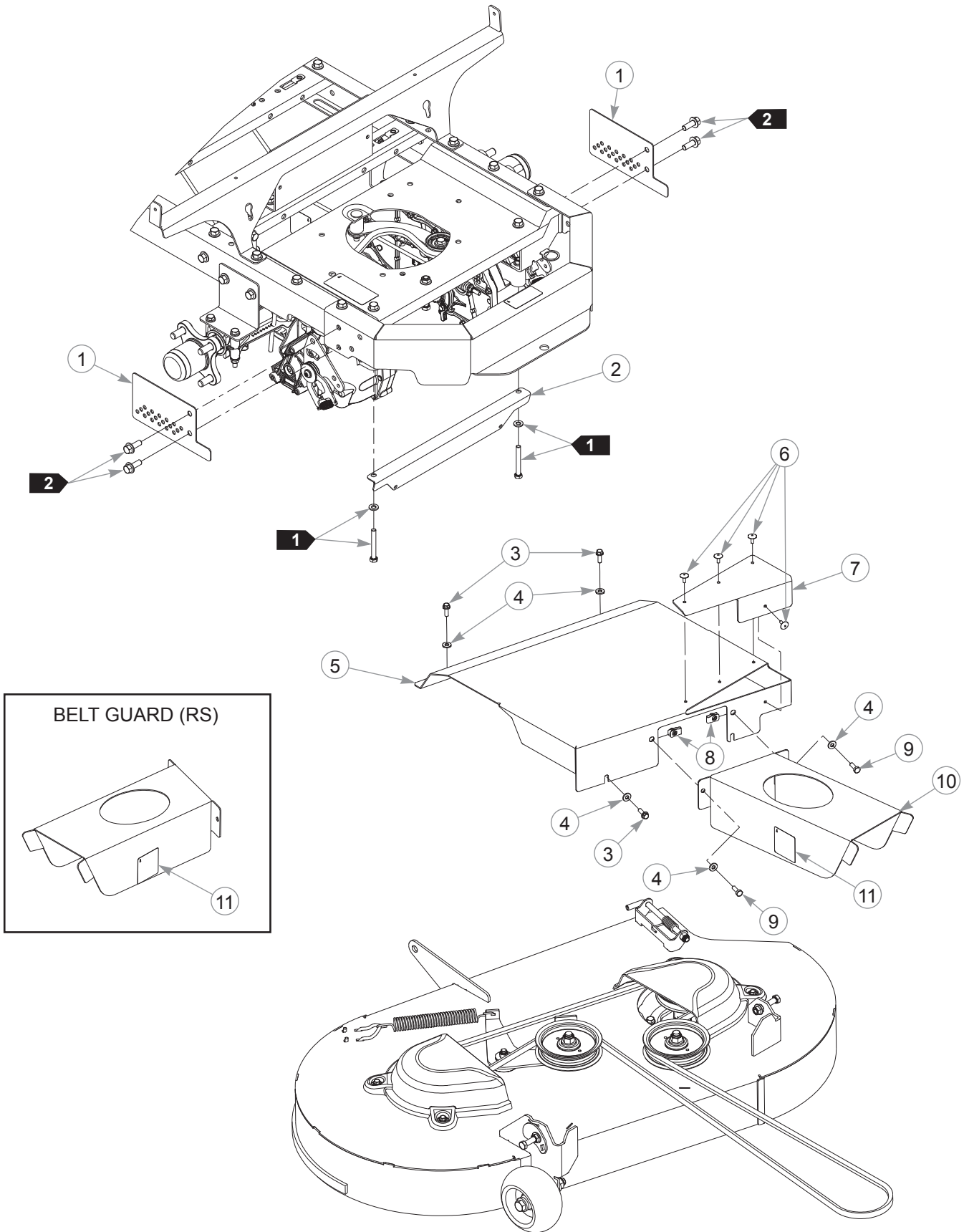

42" Guards

INDEX NO.	PART NO.	QTY.	DESCRIPTION
1	120855	2	TRANSMISSION GUARD
2	120838	1	CLUTCH GUARD
3	604324	4	CS .250-20 X .75 HX FLG
4	768515	6	FW .281 X .625 X .066
5	552973	1	PULLEY COVER (WITH DECAL AND DECK GUARD)
6	603398	4	RIVET
7	552974	1	DECK GUARD (WITH DECALS)
8	601982	2	CN .250-20 X .15 MAX THK
9	055939	2	CS .250-20 X .75 HX G5
10	120769	1	BELT GUARD, CE
11	602562	3	NO SERVICE DECAL

NOTES:

1. Part of the Hydraulic Assembly.
2. Part of the Frame.

36"/42" Deck Lift

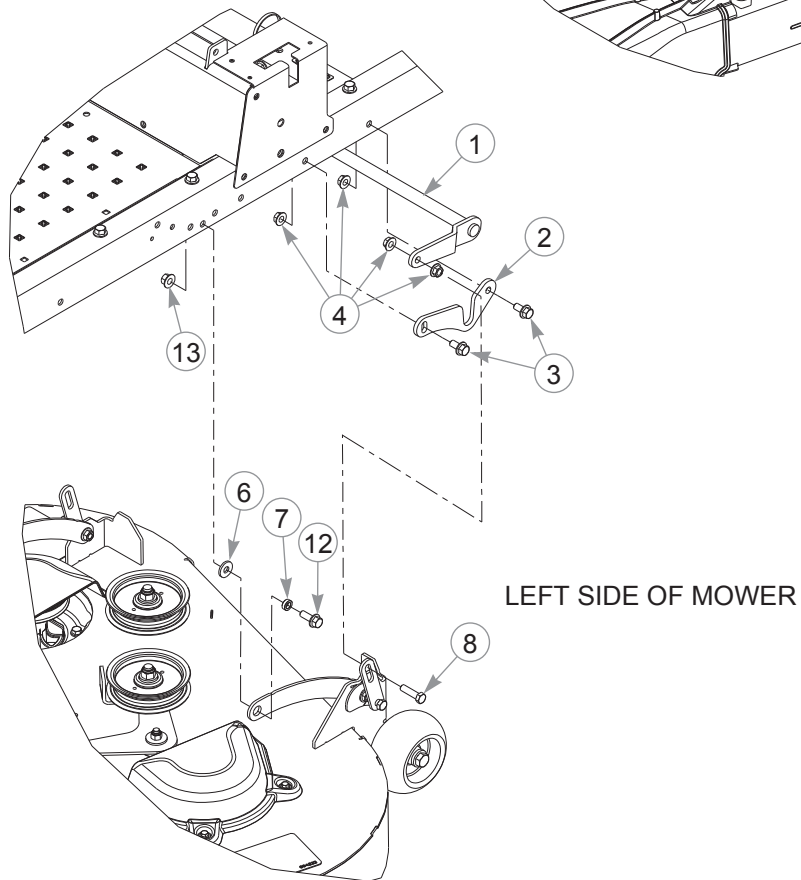
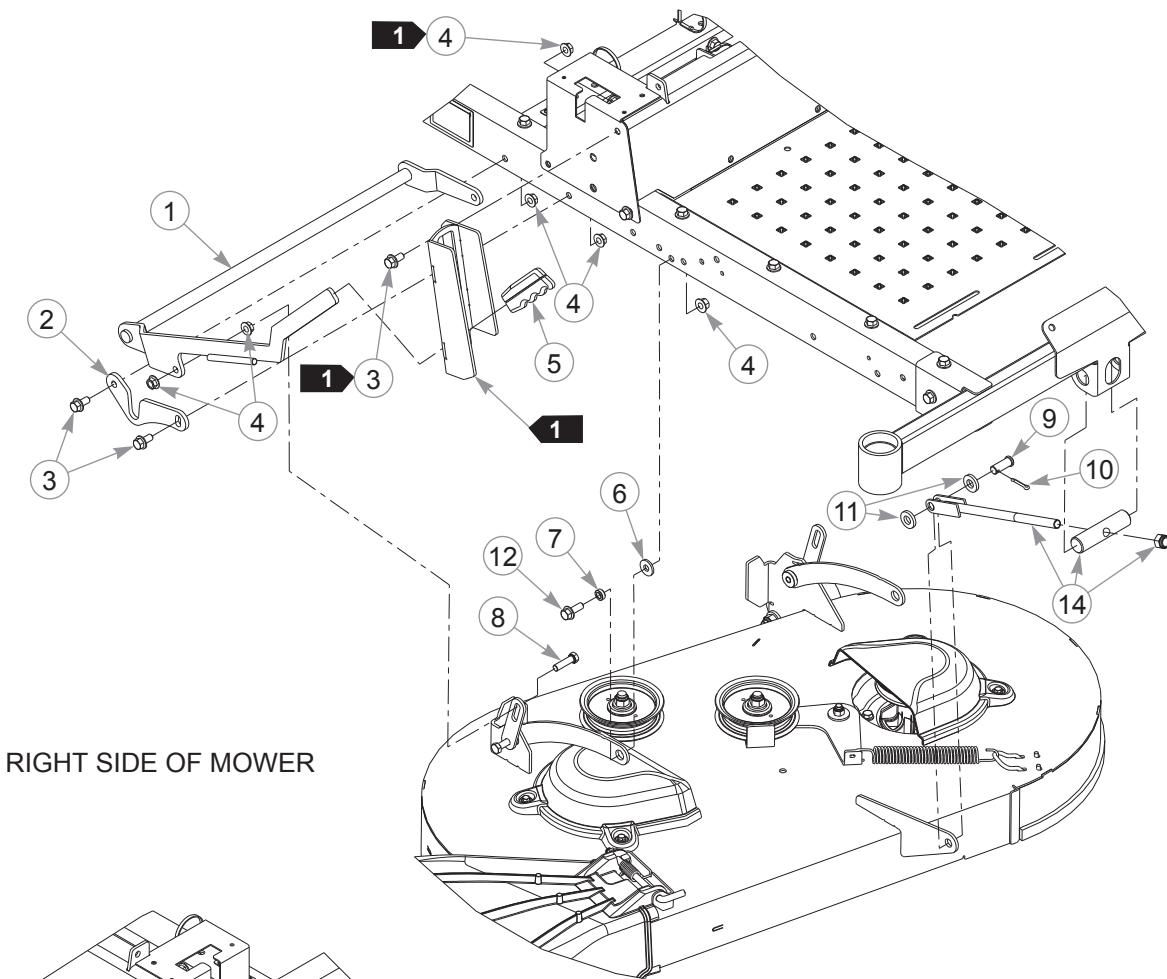

36"/42" Deck Lift

INDEX NO.	PART NO.	QTY.	DESCRIPTION
1	116156	1	LIFT HANDLE
2	116151	2	PIVOT BLOCK
3	029629	4	CS .375-16 X .75 HX FLK
4	016899	8	NT .375-16 HX FLK G5
5	604377	1	GRIP
6	712919	2	FW .406 X 1.00 X .12 HRD Z
7	601839	2	PIVOT SPACER BUSHING
8	005116	2	CS .375-16 X 1.375 HX G5
9	027714	1	CE .500 X 1.25 X .156 X 1.093
10	017251	1	CP .156D X 1.00 LG HML Z
11	767962	2	FW .531 X 1.063 X .175
12	029751	2	CS .375-16 X 1.00 HX FLK
13	604515	2	NT 0.375-16 FL NY GF
14	121232	1	DECK PIVOT KIT

NOTES:

1. Part of the Steering Cover Assembly.

Spindle Service Parts - 604214

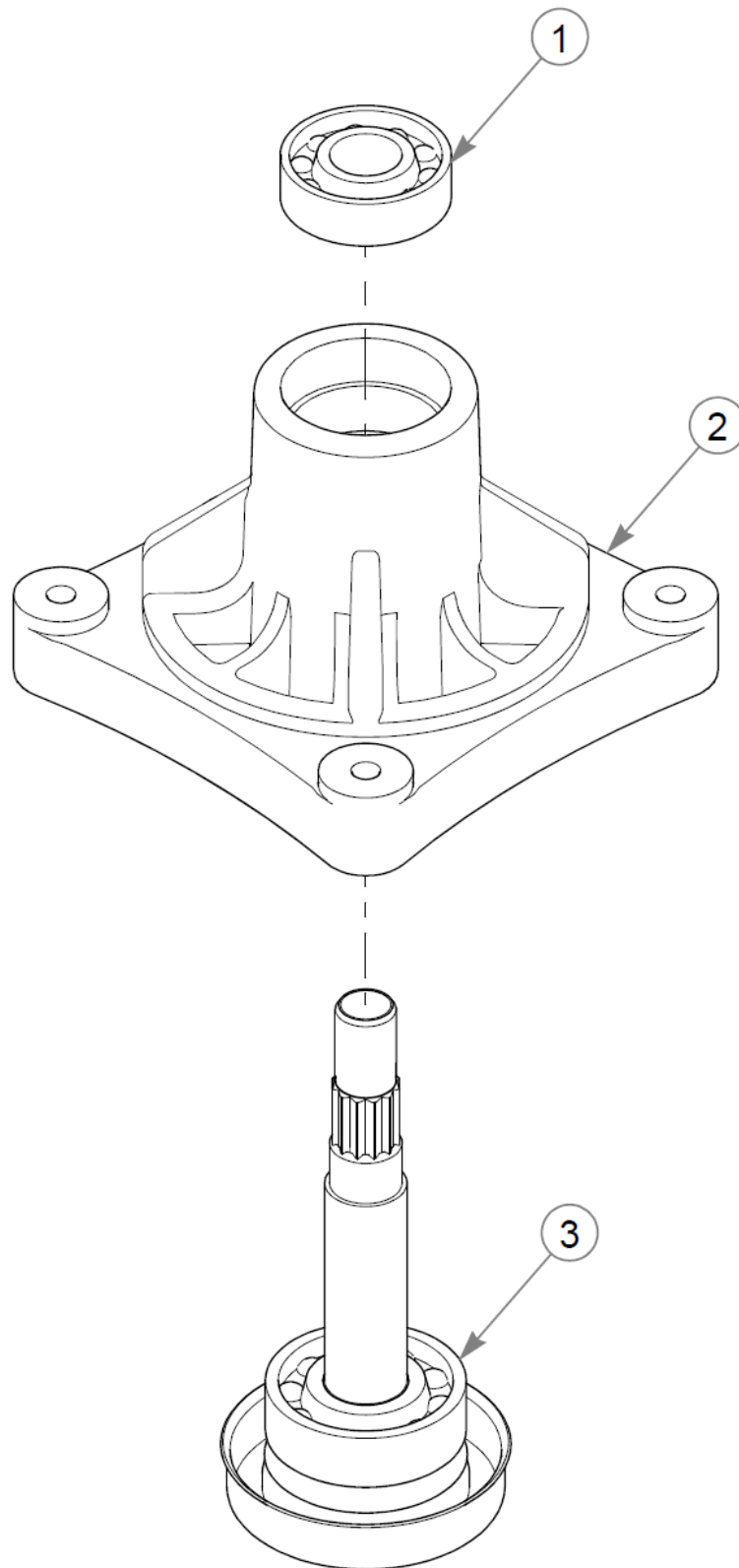

Spindle Service Parts - 604214

Item	Part No.	Qty	Name
1	604019	1	6203 2RST C3
2	604218	1	CAST HOUSING
3	607274	1	SVC SHAFT
3-1	607274-1	1	BALL BEARING 6204 2RST C3 x 607274
3-2	607274-2	1	OIL SEAL x 607274
3-3	607274-3	1	CUP PROTECTION x 607274

Section 7

Seat 7-2

Seat

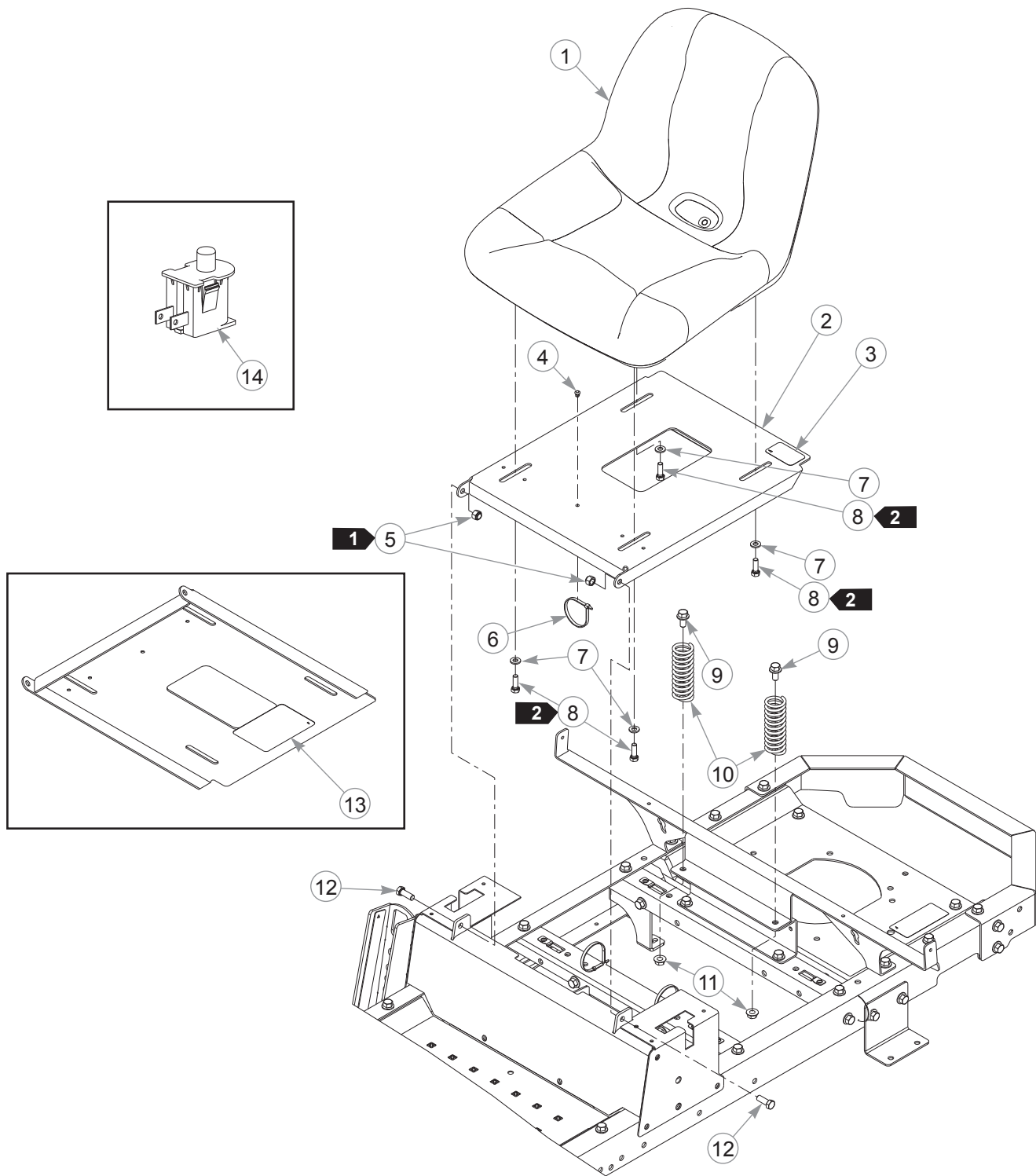

Seat

INDEX NO.	PART NO.	QTY.	DESCRIPTION
1	601807	1	STANDARD SEAT
2	551897	1	SEAT PAN (WITH DECAL)
3	605688	1	LEVEL FUEL FILL DECAL
4	604307	1	PUSH BUTTON MOUNT
5	086660	2	NT .375-16 HX ZY NL
6	000331	1	WIRE TIE
7	768523	4	FW .343 X .687 X .051/.080H
8	036236	4	CS .312-18 X 1.00 HX G5
9	029629	2	CS .375-16 X .75 HX FLK
10	793851	2	COMPRESSION SPRING 1.25 X 4.00 X .188
11	016899	2	NT .375-16 HX FLK G5
12	036244	2	CS .375-16 X 1.00 HX G5
13	601815	1	BATTERY WARNINGS DECAL
14	793315	1	SEAT SWITCH

NOTES:

1. Do not torque; the seat pan must pivot freely.
2. Torque to 9.5 N•m.

